



Agilent 75000 SERIES B

Agilent E1364A 16-Channel Form C Switch Module

User's Manual



Agilent Technologies

Copyright© Agilent Technologies, Inc., 2006



E1364-90002
E0406

Contents

Agilent E1364A Switch Module Table of Contents

Warranty	5
WARNINGS	6
Safety Symbols	6
Declaration of Conformity	7
1. Agilent E1364A Getting Started	11
Using This Chapter	11
Instrument Definition	11
Switch Description	11
Basic Operation	11
Typical Configuration	13
Programming the Switch	13
Specifying SCPI Commands	13
Switch Card Numbers	14
Switch Channel Numbers	14
Initial Operation	15
2. Configuring the Agilent E1364A Form C Switch	17
Using This Chapter	17
Warnings and Cautions	17
Connecting User Inputs	18
Typical Switch Configurations	20
General Purpose Relay Configuration	20
Relay Control Configuration	20
Digital Output Configuration	22
Changing Form C Switch Components	23
Module Front Panel Connections	24
3. Using the Agilent E1364A Form C Switch	25
Using This Chapter	25
Form C Switch Commands	25
Switching Channels	26
Switching Channels Comments	30
Scanning Channels	31
Scanning Channels Comments	32
4. Understanding the Agilent E1364A Form C Switch	33
Using This Chapter	33
Scanning Channels Commands	33
Using Scanning Trigger Sources	33
Scanning With External Instruments	33
Using the Scan Complete Bit	38
Special 488.2 Commands	39

Storing States	39
Recalling States	39
SCPI Error Responses	40
5. Agilent E1364A Form C Switch Command Reference	41
Using This Chapter	41
Command Types	41
Common Command Format	41
SCPI Command Format	41
Command Separator	42
Abbreviated Commands	42
Implied Commands	42
Parameters	43
Linking Commands	43
SCPI Command Reference	44
ABORt	44
ARM	45
:COUNT	45
:COUNT?	46
DISPlay	47
MONitor:CARD	47
MONitor[:STATe]	48
INITiate	49
:CONTInuous	49
:CONTInuous?	50
[:IMMediate]	50
OUTPut	51
[:STATe]	51
[:STATe]?	51
[ROUte:]	52
CLOSE	52
CLOSE?	53
OPEN	53
OPEN?	54
SCAN	54
SCAN:MODE	55
STATus	55
:OPERation[:EVENT]?	55
:OPERation:ENABle	56
SYSTem	56
:ERRor?	56
:CDEscription?	57
:CTYPe?	57
:CPON	58
TRIGger	58
[:IMMediate]	58
:SOURce	59
:SOURce?	60

IEEE 488.2 Common Commands	61
Command Quick Reference	62
A. Agilent E1364A Specifications	63
Relay Life	64
End of Life Detection	64
Replacement Strategy	64
B. Agilent E1364A Form C Switch Registers	65
Register Definitions	65
Addressing the Registers	66
Reading the Registers	66
ID/Device Type Registers	66
Status/Control Register	66
Channel Enable Register	67
Writing to the Registers	67
Channel Enable Register	67
C. Agilent E1364A Form C Switch Error Messages	69

Notes

Certification

Agilent Technologies certifies that this product met its published specifications at the time of shipment from the factory. Agilent Technologies further certifies that its calibration measurements are traceable to the United States National Institute of Standards and Technology (formerly National Bureau of Standards), to the extent allowed by that organization's calibration facility, and to the calibration facilities of other International Standards Organization members.

Warranty

This Agilent Technologies product is warranted against defects in materials and workmanship for a period of one year from date of shipment. Duration and conditions of warranty for this product may be superseded when the product is integrated into (becomes a part of) other Agilent products. During the warranty period, Agilent Technologies will, at its option, either repair or replace products which prove to be defective.

For warranty service or repair, this product must be returned to a service facility designated by Agilent Technologies. Buyer shall prepay shipping charges to Agilent and Agilent shall pay shipping charges to return the product to Buyer. However, Buyer shall pay all shipping charges, duties, and taxes for products returned to Agilent from another country.

Agilent warrants that its software and firmware designated by Agilent for use with a product will execute its programming instructions when properly installed on that product. Agilent does not warrant that the operation of the product, or software, or firmware will be uninterrupted or error free.

Limitation Of Warranty

The foregoing warranty shall not apply to defects resulting from improper or inadequate maintenance by Buyer, Buyer-supplied products or interfacing, unauthorized modification or misuse, operation outside of the environmental specifications for the product, or improper site preparation or maintenance.

The design and implementation of any circuit on this product is the sole responsibility of the Buyer. Agilent does not warrant the Buyer's circuitry or malfunctions of Agilent products that result from the Buyer's circuitry. In addition, Agilent does not warrant any damage that occurs as a result of the Buyer's circuit or any defects that result from Buyer-supplied products.

NO OTHER WARRANTY IS EXPRESSED OR IMPLIED. Agilent SPECIFICALLY DISCLAIMS THE IMPLIED WARRANTIES OF MERCHANTABILITY AND FITNESS FOR A PARTICULAR PURPOSE.

Exclusive Remedies

THE REMEDIES PROVIDED HEREIN ARE BUYER'S SOLE AND EXCLUSIVE REMEDIES. Agilent SHALL NOT BE LIABLE FOR ANY DIRECT, INDIRECT, SPECIAL, INCIDENTAL, OR CONSEQUENTIAL DAMAGES, WHETHER BASED ON CONTRACT, TORT, OR ANY OTHER LEGAL THEORY.

Notice

The information contained in this document is subject to change without notice. Agilent Technologies MAKES NO WARRANTY OF ANY KIND WITH REGARD TO THIS MATERIAL, INCLUDING, BUT NOT LIMITED TO, THE IMPLIED WARRANTIES OF MERCHANTABILITY AND FITNESS FOR A PARTICULAR PURPOSE. Agilent shall not be liable for errors contained herein or for incidental or consequential damages in connection with the furnishing, performance or use of this material. This document contains proprietary information which is protected by copyright. All rights are reserved. No part of this document may be photocopied, reproduced, or translated to another language without the prior written consent of Agilent Technologies, Inc. Agilent assumes no responsibility for the use or reliability of its software on equipment that is not furnished by Agilent.

U.S. Government Restricted Rights

The Software and Documentation have been developed entirely at private expense. They are delivered and licensed as "commercial computer software" as defined in DFARS 252.227-7013 (Oct 1988), DFARS 252.211-7015 (May 1991) or DFARS 252.227-7014 (Jun 1995), as a "commercial item" as defined in FAR 2.101(a), or as "Restricted computer software" as defined in FAR 52.227-19 (Jun 1987)(or any equivalent agency regulation or contract clause), whichever is applicable. You have only those rights provided for such Software and Documentation by the applicable FAR or DFARS clause or the Agilent standard software agreement for the product involved.

Agilent E1364A 16-Channel Form C Switch User's Manual
Edition 2 Rev 2

Copyright © 1995-2006 Agilent Technologies, Inc. All Rights Reserved.

Printing History

The Printing History shown below lists all Editions and Updates of this manual and the printing date(s). The first printing of the manual is Edition 1. The Edition number increments by 1 whenever the manual is revised. Updates, which are issued between Editions, contain replacement pages to correct the current Edition of the manual. Updates are numbered sequentially starting with Update 1. When a new Edition is created, it contains all the Update information for the previous Edition. Each new Edition or Update also includes a revised copy of this printing history page. Many product updates or revisions do not require manual changes and, conversely, manual corrections may be done without accompanying product changes. Therefore, do not expect a one-to-one correspondence between product updates and manual updates.

Edition 1 (Part Number E1364-90001) September 1989

Edition 2 (Part Number E1364-90002) April 1995

Edition 2 Rev 2 (Part Number E1364-90002) April 2006

Safety Symbols



Instruction manual symbol affixed to product. Indicates that the user must refer to the manual for specific **WARNING** or **CAUTION** information to avoid personal injury or damage to the product.



Alternating current (AC).



Direct current (DC).



Indicates hazardous voltages.



Indicates the field wiring terminal that must be connected to earth ground before operating the equipment—protects against electrical shock in case of fault.

WARNING

Calls attention to a procedure, practice, or condition that could cause bodily injury or death.

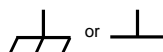

Frame or chassis ground terminal—typically connects to the equipment's metal frame.

CAUTION

Calls attention to a procedure, practice, or condition that could possibly cause damage to equipment or permanent loss of data.

WARNINGS

The following general safety precautions must be observed during all phases of operation, service, and repair of this product. Failure to comply with these precautions or with specific warnings elsewhere in this manual violates safety standards of design, manufacture, and intended use of the product. Agilent Technologies assumes no liability for the customer's failure to comply with these requirements.

Ground the equipment: For Safety Class 1 equipment (equipment having a protective earth terminal), an uninterruptible safety earth ground must be provided from the mains power source to the product input wiring terminals or supplied power cable.

DO NOT operate the product in an explosive atmosphere or in the presence of flammable gases or fumes.

For continued protection against fire, replace the line fuse(s) only with fuse(s) of the same voltage and current rating and type. DO NOT use repaired fuses or short-circuited fuse holders.

Keep away from live circuits: Operating personnel must not remove equipment covers or shields. Procedures involving the removal of covers or shields are for use by service-trained personnel only. Under certain conditions, dangerous voltages may exist even with the equipment switched off. To avoid dangerous electrical shock, DO NOT perform procedures involving cover or shield removal unless you are qualified to do so.

DO NOT operate damaged equipment: Whenever it is possible that the safety protection features built into this product have been impaired, either through physical damage, excessive moisture, or any other reason, REMOVE POWER and do not use the product until safe operation can be verified by service-trained personnel. If necessary, return the product to an Agilent Technologies Sales and Service Office for service and repair to ensure that safety features are maintained.

DO NOT service or adjust alone: Do not attempt internal service or adjustment unless another person, capable of rendering first aid and resuscitation, is present.

DO NOT substitute parts or modify equipment: Because of the danger of introducing additional hazards, do not install substitute parts or perform any unauthorized modification to the product. Return the product to an Agilent Technologies Sales and Service Office for service and repair to ensure that safety features are maintained.



Manufacturer's Name: Agilent Technologies, Incorporated
Manufacturer's Address: 815 – 14th St. SW
Loveland, Colorado 80537
USA

Declares, that the product

Product Name: VXI B-Size 16 Channel Form C Switch
Model Number: E1364A
Product Options: *This declaration covers all options of the above product(s).*

Conforms with the following European Directives:

The product herewith complies with the requirements of the Low Voltage Directive 73/23/EEC and the EMC Directive 89/336/EEC (including 93/68/EEC) and carries the CE Marking accordingly.

Conforms with the following product standards:

EMC	Standard	Limit
	CISPR 11:1990 / EN 55011:1991	Group 1 Class A
	IEC 801-2:1991 / EN 50082-1:1992	4kV CD, 8kV AD
	IEC 801-3:1984 / EN 50082-1:1992	3 V/m
	IEC 801-4:1988 / EN 50082-1:1992	0.5kV signal lines, 1kV power lines

The product was tested in a typical configuration with Agilent Technologies or Hewlett-Packard Company test systems.

Safety IEC 1010-1:1990+A1:1992 / EN 61010-1:1993
Canada: CSA C22.2 No. 1010.1:1992
UL 1244

5 June 2001
Date

Ray Corson
Product Regulations Program Manager

For further information, please contact your local Agilent Technologies sales office, agent or distributor.
Authorized EU-representative: Agilent Technologies Deutschland GmbH, Herrenberger Strabe 130, D 71034 Böblingen, Germany

Notes

Notes

Notes

Chapter 1

Getting Started with the Agilent E1364A

Using This Chapter

This chapter includes a Form C Switch description, addressing guidelines, and an example program to check initial operation. Chapter contents are:

- Instrument Definition Page 11
- Programming the Switch Page 13
- Initial Operation Page 15

Instrument Definition

Agilent plug-in modules installed in an Agilent mainframe are treated as independent instruments each having a unique secondary GPIB address. Each instrument is also assigned a dedicated error queue, input and output buffers, status registers and, if applicable, dedicated mainframe memory space for readings or data. An instrument may be composed of a single plug-in module or multiple plug-in modules (for a Switchbox or Scanning Voltmeter Instrument).

Switch Description

The Agilent E1364A 16-Channel Form C Switch Module is a B-Size VXIbus and VMEbus register-based product which can be used for switching/scanning, control, and digital output applications. The switch can operate in a B-Size VXIbus or VMEbus mainframe or (with an adapter) in a C-Size VXIbus mainframe. The module has 16 channels of Form C relays. Each channel includes a relay with common (C), normally open (NO), and normally closed (NC) contacts.

For the Form C Switch, switching consists of opening or closing a channel relay to provide alternate connections to user devices. Scanning consists of closing a set of relays, one at a time. By adding jumpers and pullup/pulldown resistors, the switch can be used to control external user devices or as a digital output device.

Basic Operation

As shown in Figure 1-1, the Form C Switch consists of 16 channels (channels 00 through 15). Each channel uses a latching relay. As required, jumpers can be added to connect +5 V or +12 V for control or digital output applications. Also, pullup resistors can be added for digital output applications.

Each channel is switched by opening or closing the appropriate channel relay. Since the relays are latching, the relay remains in the last state during power-up or power-down. When a reset occurs, all channel commons (C) are connected to the corresponding normally closed (NC) contacts. User inputs/outputs to each channel are via the NO, NC, and C terminal connectors on the terminal module.

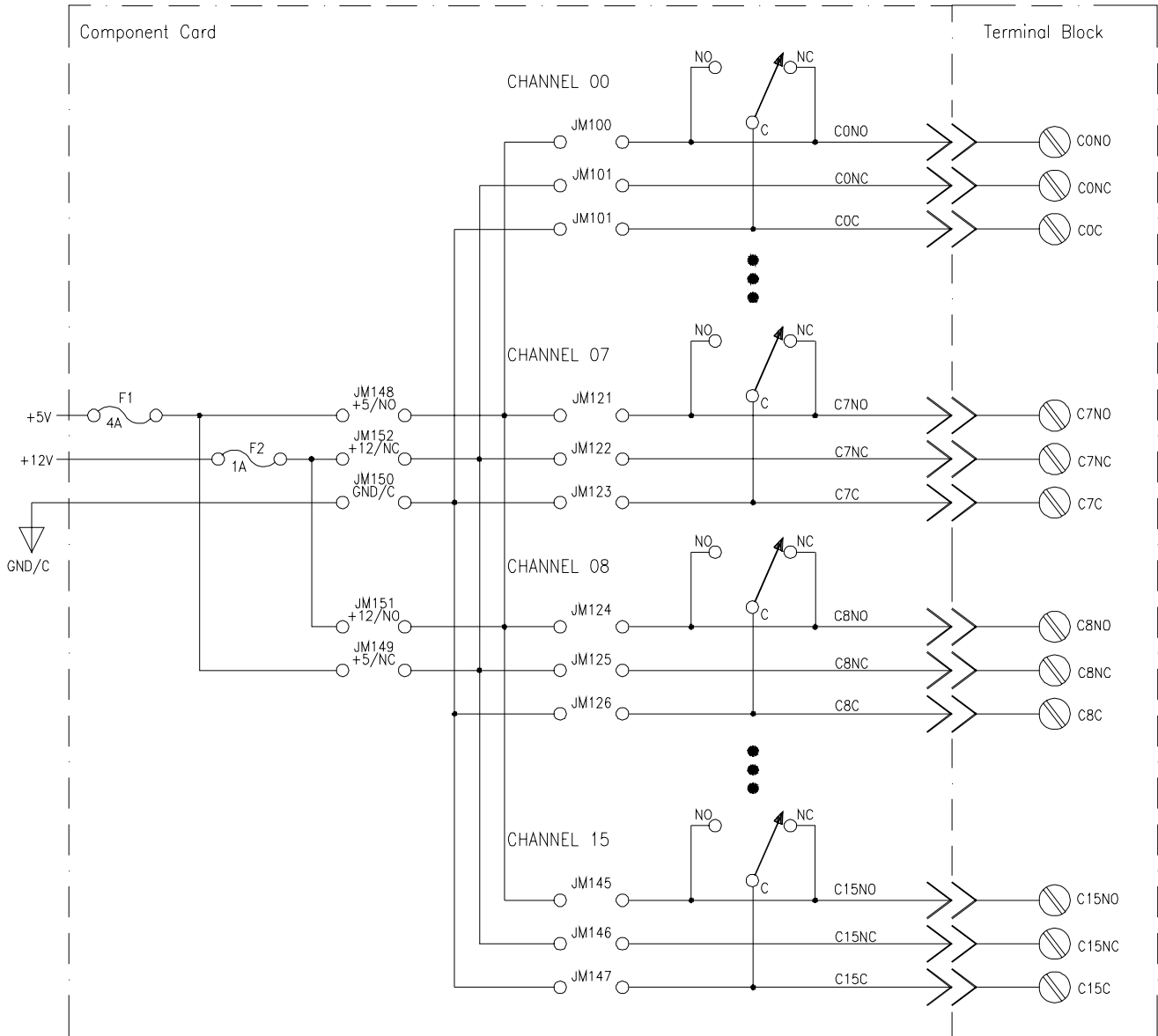

Figure 1-1. Form C Switch Simplified Diagram

Typical Configuration

The Form C Switch accepts user inputs up to 250 V dc or 250 V ac peak (177 V ac RMS) at 1 A dc or ac RMS (non-inductive). Maximum rated power capacity is 30 W or 40 VA per channel. Channel closure time is about 15 msec, so the maximum scan rate is about 50 Hz.

As noted, the switch may be configured for general purpose switching/scanning, control, or digital output applications. For general purpose switching or scanning, no additional configuration is required. To configure the switch for control applications, install jumpers to connect a + 5V or + 12V source and GND. To configure the switch for digital output applications, connect jumpers and install pullup/pulldown resistors as required. See Chapter 2 for configuration details.

For a SCPI (Standard Commands for Programmable Instruments) environment, multiple Form C Switches can be configured as a switchbox instrument. For a switchbox instrument, all switch channels within the instrument can be addressed using a single interface address. Single, multiple, or continuous scanning of specified switch channels is available for any switchbox configuration.

Programming the Switch

To program the Form C Switch using SCPI, you must know the module's logical address, module number, and the SCPI commands to be used. Guidelines to select SCPI commands for the Form C Switch follow. See the *Agilent 75000 Series B Installation and Getting Started Guide* for interface addressing and computer language information.

Note

This discussion applies only to SCPI (Standard Commands for Programmable Instruments) programming. See Appendix B, *Form C Switch Registers*, for information on Form C Switch registers.

Specifying SCPI Commands

To address specific channels within a Form C Switch, you must specify the SCPI command and switch channel address. For the Form C Switch, use `CLOSE <channel_list>` to connect the normally open (NO) terminal to the common (C) terminal for the channels specified. Use `OPEN <channel_list>` to connect the normally closed (NC) terminal to the common (C) terminal for the channels specified. Use `SCAN <channel_list>` to close the set of channels specified, one channel at a time.

Switch Channel Addresses

For the Form C Switch, the channel address (`<channel_list>`) has the form (`@ccnn`) where `cc` = switch card number (01-99) and `nn` = channel numbers (00-15).

You can address single channels (@ccnn); multiple channels (@ccnn,ccnn,...); sequential channels (@ccnn:ccnn); groups of sequential channels (@ccnn:ccnn,ccnn:ccnn); or any combination.

Switch Card Numbers

The switch card number depends on the switchbox configuration (single-module or multiple-module) set for the switches. (Leading zeroes can be ignored for the card number.) For a single-module switchbox, the card number is always 01.

For a multiple-module switchbox, the card numbers are 01, 02,...,nn. The module with the lowest logical address is card number 01, the module with the next-lowest logical address is card number 02, etc. (See the *Agilent 75000 Series B Installation and Getting Started Guide* for a definition of logical addresses.)

Example: Multiple-Module Switchbox Card Numbers

Assume the three Form C Switches in the following figure form a switchbox instrument with switch logical addresses of 120, 121, and 122. Since card number 01 is assigned to the module with the lowest logical address, etc., the card numbers are as shown.

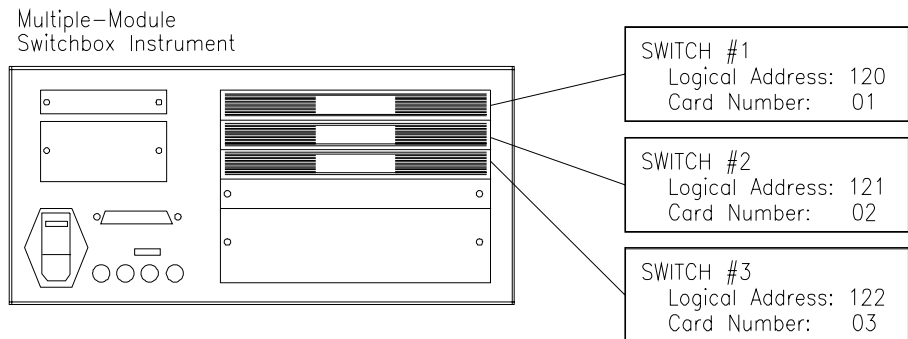

Switch Channel Numbers

Form C Switch channel numbers are 00 through 15. The channels can be addressed using channel numbers or channel ranges. For a single-module switchbox, channel ranges can span across the channels. For multiple-module switchboxes, channel ranges can span across the channels of all modules.

Use commas (,) to form a channel list or use a colon (:) to form a channel range. Only valid channels can be accessed in a channel list or channel range. Also, the channel list or channel range must be from a lower channel number to a higher channel number. For example, CLOS (@100:215) is acceptable, but CLOS (@215:100) generates an error.

Example: Form C Switch Channel Lists/Ranges

Channel Lists:

CLOS (@100,112)	<i>Close channels 00 and 12 on card 01</i>
OPEN (@203,210)	<i>Open channels 03 and 10 on card 02</i>

Channel Ranges:

OPEN (@100:115)	<i>Open all channels on card 01</i>
SCAN (@100:115)	<i>Scan all channels on card 01</i>

Initial Operation

An example program follows which uses BASIC and the SCPI language to get you started using the Form C Switch. The example assumes an Agilent 9000 Series 200/300 (or equivalent) computer and a General Purpose Interface Bus (GPIB). (GPIB is the implementation of the IEEE 488.2-1987 standard.)

This program closes channel 02 of a Form C Switch at logical address 120 (secondary address = $120/8 = 15$) and queries the channel closure state. The result is returned to the computer and displayed (1 = channel closed, 0 = channel open). See the *Agilent 75000 Series B Installation and Getting Started Guide* for information on addressing.

Example: Close Form C Switch Channel

```
10 OUTPUT 70915;"CLOS (@102)"      ! Close channel 02
20 OUTPUT 7091 5;"CLOS? (@102)"    ! Query channel 02 state
30 ENTER 70915;Value               ! Enter result into Value
40 PRINT Value                      ! Display result
50 END
```

Chapter 2

Configuring the Agilent E1364A Form C Switch

Using This Chapter

This chapter shows how to make user connections to the Form C Switch and how to configure the switch module. Chapter contents are:

- Warnings and Cautions Page 17
- Connecting User Inputs Page 18
- Typical Switch Configurations Page 20
- Changing Form C Switch Components Page 23
- Module Front Panel Connections Page 24

Warnings and Cautions

Warning **SHOCK HAZARD. Only qualified, service-trained personnel who are aware of the hazards involved should install, configure, or remove the module. Use wire rated for the highest input voltage and remove all power sources from the mainframe and installed modules before installing or removing a module.**

Caution **MAXIMUM VOLTAGE/CURRENT.** Maximum allowable voltage per channel for the module is 250 Vdc or 250 Vac RMS (350 V ac peak). Maximum current per channel is 1 Adc or 1 Aac RMS (non-inductive). Maximum power input is 40 W (dc) or 40 VA (ac) per channel or 320 W (dc) or 320 VA (ac) per module. Exceeding any limit may damage the module.

Caution **CONNECTING + 5V + 12V:** On the module, the backplane + 5V line is fused at 4 A and the + 12V line at 1 A. When connecting + 5V or + 12V to the Form C Switch, install appropriate pullup resistors to prevent shorting the power supplies. Also, the total current drawn by all circuits connected to the Form C Switch must not exceed the fuse rating for the supplies used.

Caution

STATIC-SENSITIVE DEVICE. Use anti-static procedures when removing, configuring, and installing a module. The Form C Switch is susceptible to static discharges. Do not install the Form C Switch without its metal shield attached.

Connecting User Inputs

The Form C Switch consists of a component module and a connector block. User inputs to the Form C Switch are to the NO, NC, and C terminal connectors on the terminal block. Figure 2-1 shows the connector block and associated channel numbers. Figure 2-2 shows how to connect user (field) wiring to the connector block.

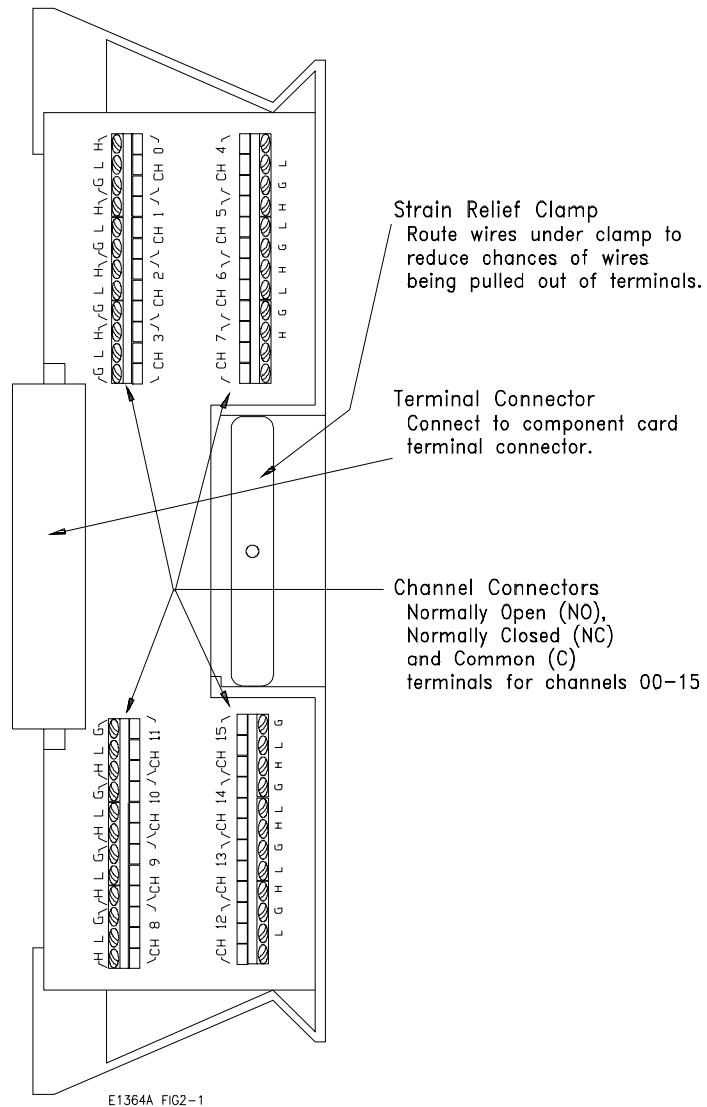
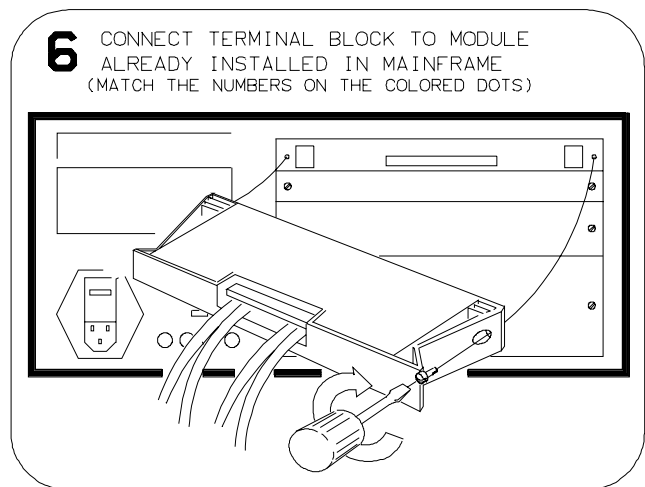
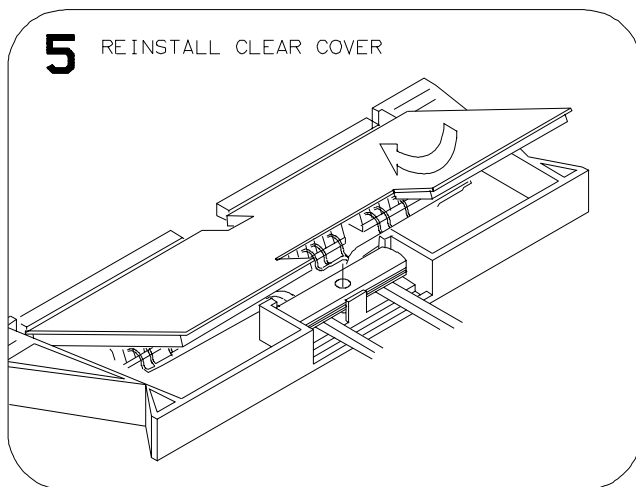
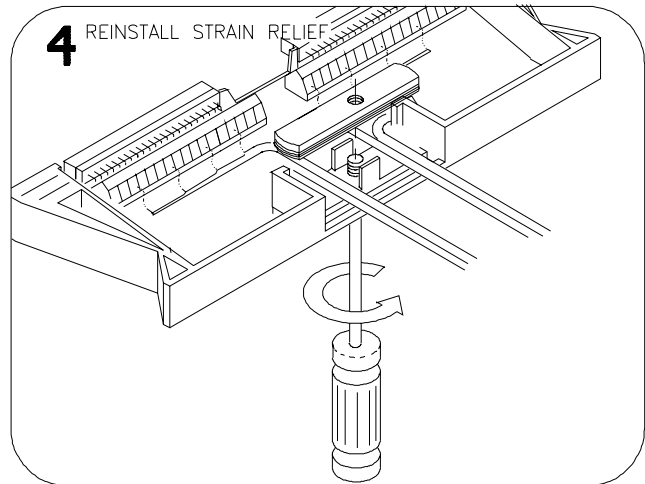
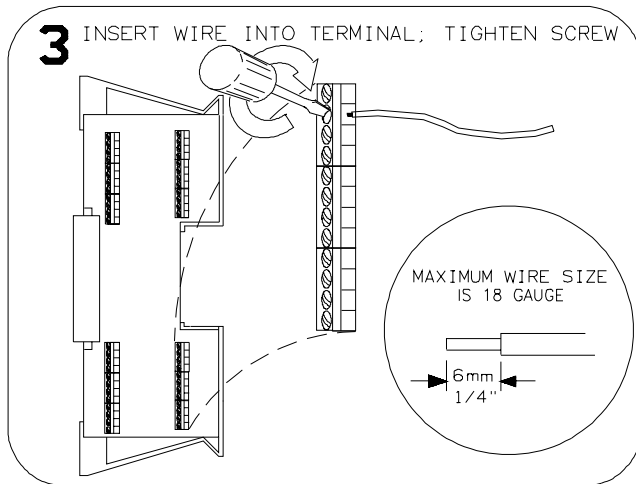
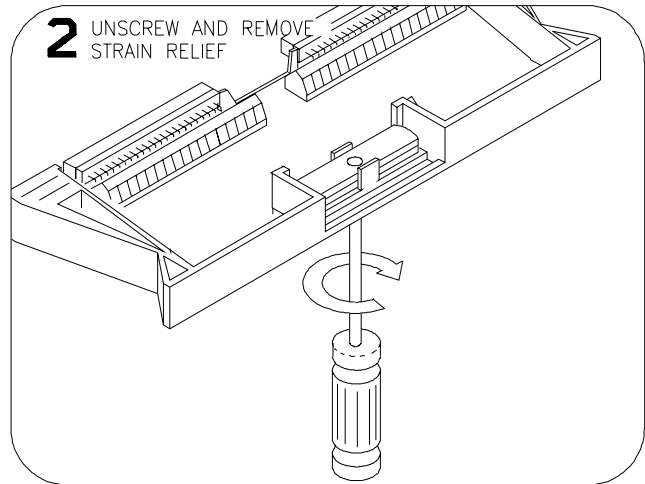
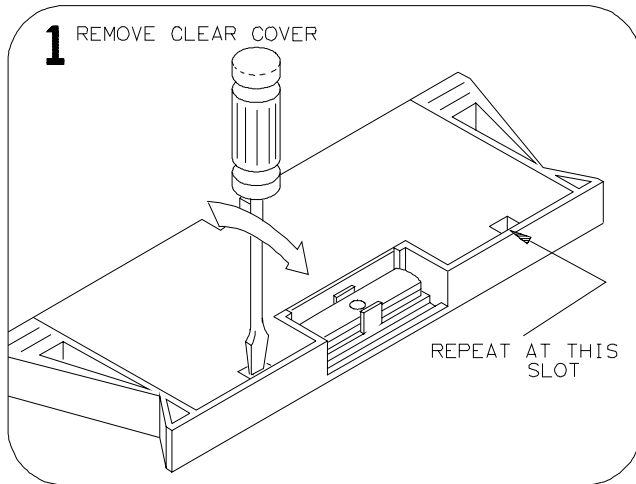

Figure 2-1. Form C Switch Terminal Block



E1364 F2-2

Figure 2-2. Wiring the Form C Switch Terminal Block

Typical Switch Configurations

Typical Form C Switch configurations are:

- General purpose relay
- Relay control
- Digital output

General Purpose Relay Configuration

As factory configured, the Form C Switch is set for general purpose relay configuration. For this configuration, you can switch channels by opening or closing channel relays or you can scan a set of channels.

Example: General Purpose Relay Configuration

Figure 2-3 shows a typical general purpose relay configuration for channel 00. When the relay is open, the NC terminal is connected to the C terminal and Load 1 is connected. When the relay is closed, the NO terminal is connected to the C terminal and Load 2 is connected.

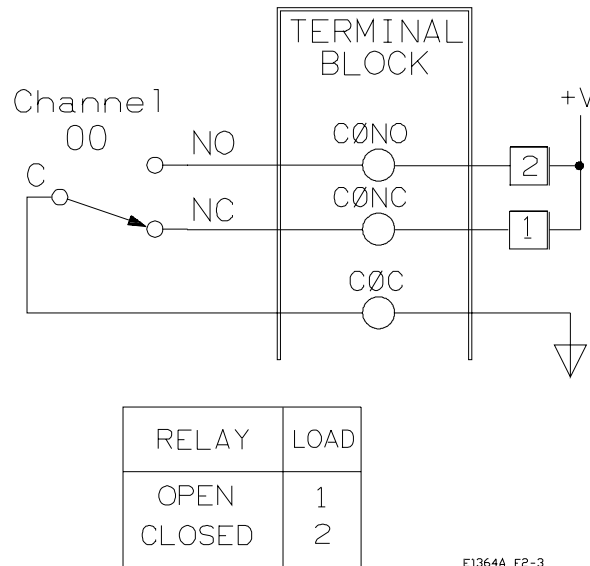

Figure 2-3. Example: General Purpose Relay Configuration

Relay Control Configuration

By connecting jumpers, you can use the Form C Switch to drive (control) external relays. The source can be +5V/NO, +5V/NC, +12V/NO, or +12V/NC depending on the jumpers connected on the switch. (See Figure 1-1 in Chapter 1 for jumper numbers and see Figure 2-6 for jumper locations.)

Note

When connecting the +5V or +12V backplane sources, the total current draw should not exceed 1 A per Form C Switch for the +5V supply or 0.5 A per Form C Switch for the +12V supply. You should fuse all external equipment to ensure excess current is not drawn.

Example: Relay Control Configuration

Figure 2-4 shows one way to control external relays using the +5V/NO source. For this example, channel 15 is dedicated to provide the +5V source to external relays 1 and 2. When the Form C Switch channel 00 relay is open, external relay 1 is connected to ground and +5V is applied to external relay 1. When the Form C Switch channel 00 is closed, external relay 2 is connected to ground and +5V is applied to external relay 2.

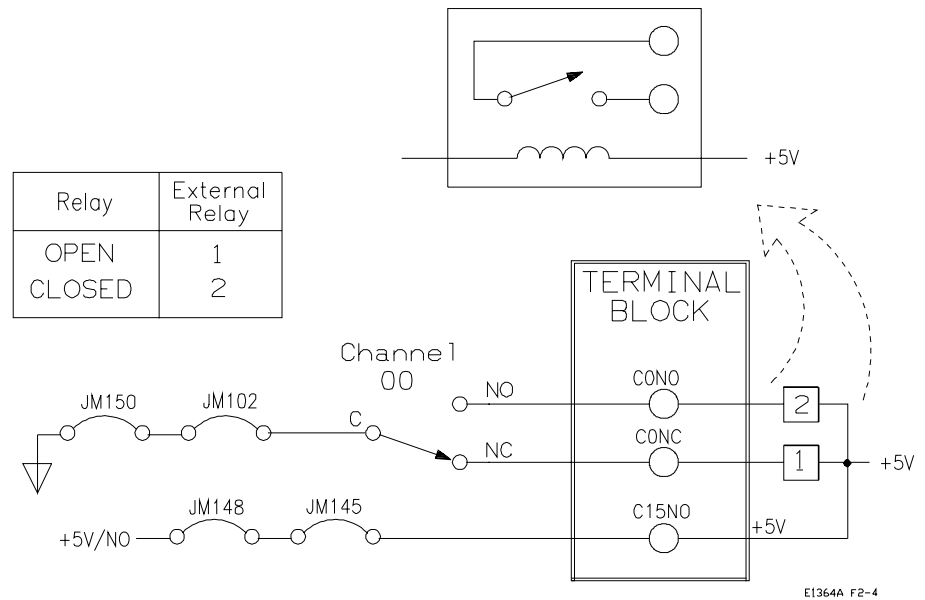

Figure 2-4. Example: Relay Control Configuration

Digital Output Configuration

By connecting jumpers and installing pullup/pulldown resistors, you can configure the switch as a digital output device.

Note

When connecting the + 5V or + 12V backplane sources for digital output operation, you must install pullup resistors on the Form C Switch for the supplies used. Also, the total current drawn by user circuits should not exceed 1 A per Form C Switch for the + 5V supply or 0.5 A per Form C Switch for the + 12V supply. You should fuse all external equipment to ensure excess current is not drawn.

Example: Digital Output Configuration

Figure 2-5 shows channel 00 configured for digital output operation. When the channel 00 relay is open (NC connected to C), point A is at + 5V. When the channel 00 relay is closed (NO connected to C), point A is at 0V.

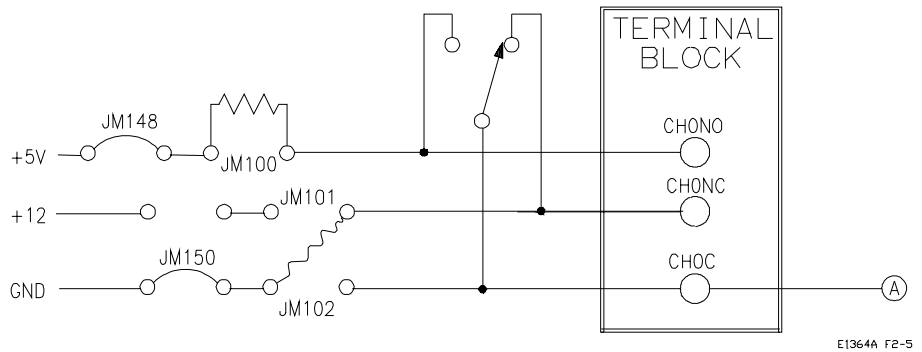

Figure 2-5. Example: Digital Output Configuration

Changing Form C Switch Components

As required, you can:

- Change the Logical Address switch setting
- Change interrupt priority jumper positions
- Replace fuses on the switch component module

See Figure 2-6 for component locations.

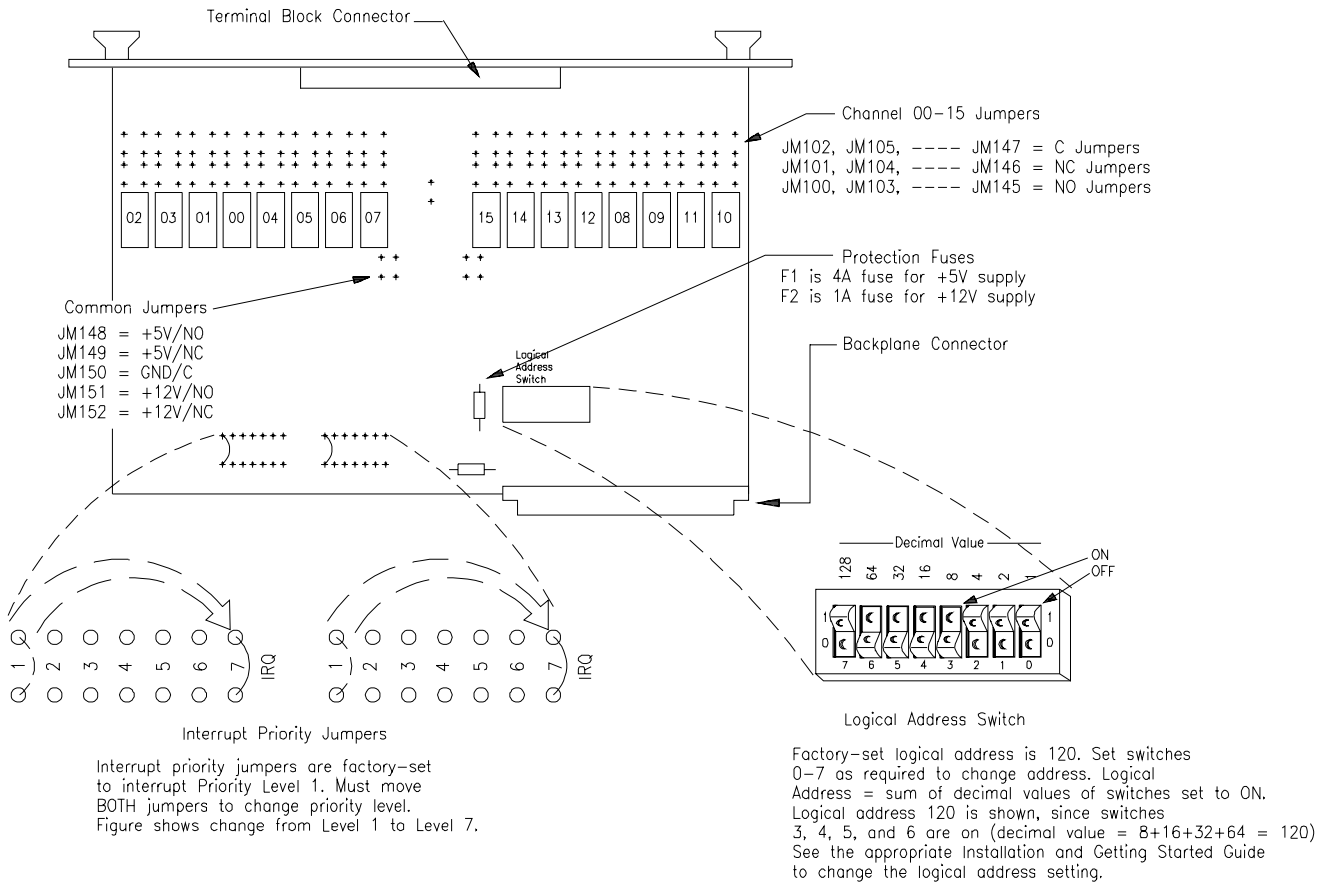

Figure 2-6. Form C Switch Component Locations

Module Front Panel Connections

If you choose not to use the supplied connector block, Figure 2-7 shows the E1364A front panel and the connection diagram for wiring your own terminal connector.

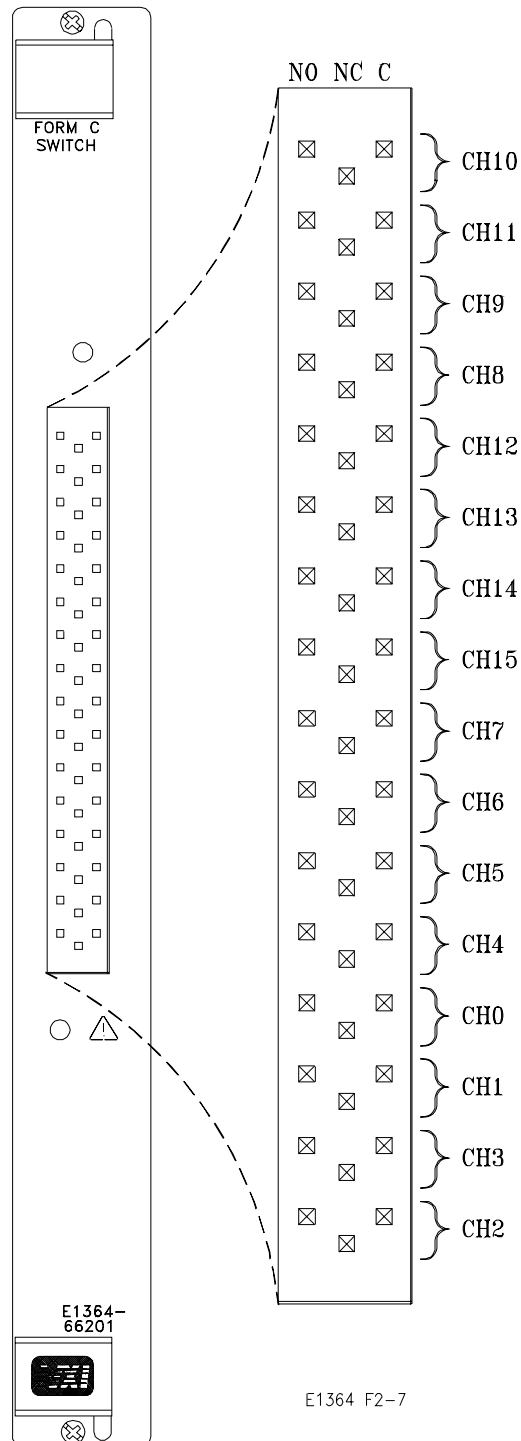

Figure 2-7. E1364A Front Panel and Wiring Diagram

Chapter 3

Using the Agilent E1364A Form C Switch

Using This Chapter

This chapter provides examples to use the Form C Switch for switching channels and scanning channels. As required see Chapter 4, Understanding the Form C Switch, for further information on scanning channels. See Chapter 5, Form C Switch Command Reference, for command information. Chapter contents are:

- Form C Switch Commands Page 25
- Switching Channels Page 26
- Scanning Channels Page 31

Form C Switch Commands

Table 3-1. Form C Switch Commands in Chapter 3

Command	Description
INIT[:IMM]	Starts the scan sequence and closes the first channel in the channel list.
OUTP[:STAT] ON	Enables the Agilent E1300B/E1301B Trig Out port to output pulses.
[ROUT:]CLOS <channel_list>	Closes the channels in the channel list.
[ROUT:]CLOS? <channel_list>	Queries the state of the channels in the channel list.
[ROUT:]OPEN <channel_list>	Opens the channels in the channel list.
[ROUT:]SCAN <channel_list>	Closes the channels in the channel list, one channel at a time.
TRIG:SOUR BUS EXT HOLD IMM	Selects the trigger source to advance the scan.

Switching Channels

For general purpose relay operation, you can connect or disconnect a load by opening or closing specified channel relays. By adding jumpers and/or pullup/pulldown resistors, the switch can be configured for relay control or digital output operations.

Use CLOS *<channel_list>* to connect a channel's normally open (NO) terminal to its common (C) terminal or use OPEN *<channel_list>* to connect a channel's normally closed (NC) contact to its common (C) terminal. *<channel_list>* has the form (@ccnn) where cc = card number (01-99) and nn = channel number (00-15).

Example: Voltage Switching

This example closes channel 00 of a Form C Switch to switch the load voltage (E) from Load 1 to Load 2. When the channel relay is open, the load voltage is applied to Load 1. When the relay is closed, the voltage is applied to Load 2. See Figure 3-1 for typical user connections. To close channel 00, execute:

CLOS (@100)

Close channel 00 relay (connect NO to C). 1 is the card number and 00 is the channel number.

To open channel 00, use OPEN (@100).

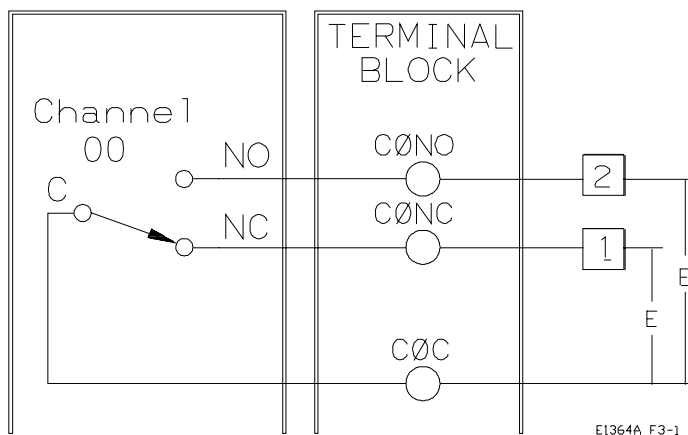

Figure 3-1. Example: Voltage Switching

Example: Controlling Microwave Relays

This example shows one way that the Form C Switch can be used to control an (external) microwave relay. Figure 3-2 shows an Agilent 33311B Microwave Relay connected to channel 00 of a Form C Switch. The + 5V source for the microwave relay is provided via channel 15 of the Form C Switch (via JM148, JM145, and the channel 15NO terminal).

With this configuration, the Form C Switch provides a ground path for the coil current of the microwave relay. For example, with the Form C Switch channel 00 relay open (NC connected to C), a ground path (via the channel 0NC terminal, the channel 00 relay, JM102, and JM150) is provided for the NC side of the microwave relay.

When the microwave relay NC contact is closed, + 5V is applied to the microwave NC coil and the coil is energized. The same actions occur for the NO side of the microwave relay if the Form C Switch channel 00 relay is closed (NO connected to C). To close channel 00, execute:

CLOSE (@100)

Close channel 00 relay (connect NO to C). 1 is the card number and 00 is the channel number.

To open channel 00, use OPEN (@100).

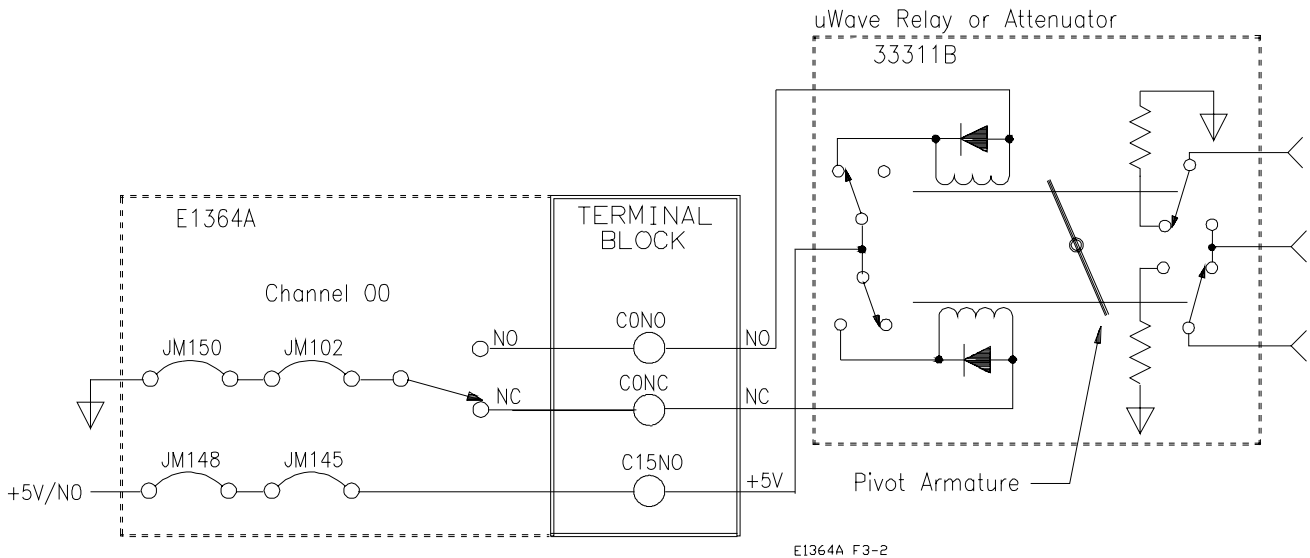

NOTES:

1. Channel 15 is dedicated to supplying + 5V to the microwave relay. The + 5V supply can be used to supply other external relays connected to the channel 15NO terminal.

2. For this configuration, power to the external relays is limited to 4A maximum, 1A typical per Form C Switch. You can use separate, external power supplies to supply more than 4A or to supply voltages other than

Figure 3-2. Example: Controlling Microwave Relays

Example: Controlling RF Switches/Step Attenuators

Figure 3-3 shows one way to drive Agilent 8761 SPDT RF Switches or Agilent 33300 Series Programmable Step Attenuators. (Figure 3-3 only shows control for the Agilent 33300 40 dB step. Additional drive relays are required for the 10 dB and 20 dB steps.) The Agilent 8761A and Agilent 33300A/C operate from a 12-15V coil voltage, while the Agilent 8761B and Agilent 33300B/D operate from a 24V-30V coil voltage. For example, to close channel 00, execute:

CLOS (@100)

Close channel 00 relay (connect NO to C). 1 is the card number and 00 is the channel number

To open channel 00, use OPEN (@100).

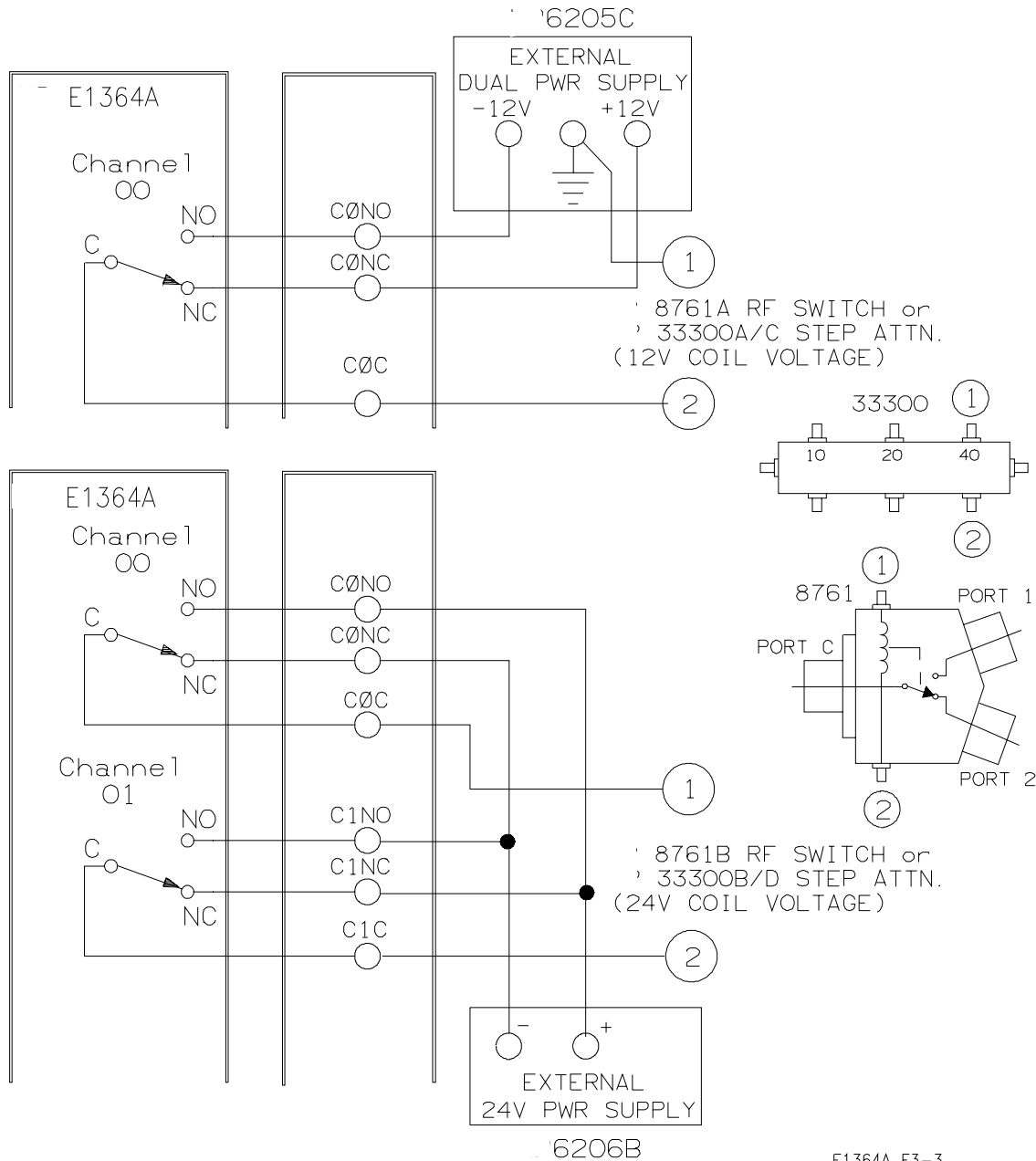

Figure 3-3. Example: Controlling RF Switches/Step Attenuators

Example: Digital Output Configuration

Figure 3-4 shows channel 00 configured for digital output operation. When the channel 00 relay is open (NC connected to C), point 1 is at + V and point 2 is at 0 V. When the channel 00 relay is closed (NO connected to C), points 1 and 2 are both at 0 V. (This configuration is useful for 24V or 48V control logic, since this type of application cannot be met with the configuration shown in Chapter 2, Figure 2-5.) To close channel 00, execute:

CLOS (@100)

Close channel 00 relay (connect NO to C). 1 is the card number and 00 is the channel number.

To open channel 00, use OPEN (@100).

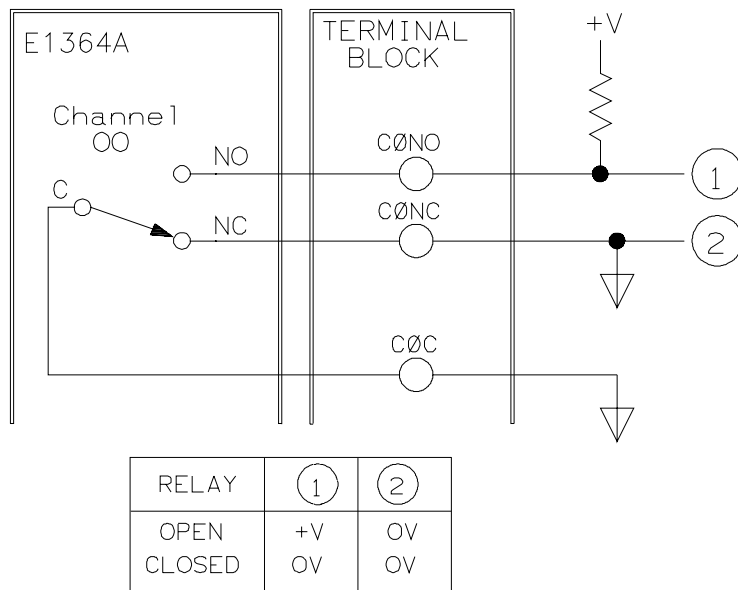

E1364A F3-4

Figure 3-4. Example: Digital Output Configuration

Example: Matrix Switching

The Form C Switch can be configured as a 4 x 4 single-wire matrix to connect any combination of up to four user sources (S0, S1, S2, and S3) to any combination of up to four user instruments (I0, I1, I2, and I3) at a time. Figure 3-5 shows a typical configuration. This example closes channel 02 to correct S2 to I0 and closes channel 13 to connect S1 to I3. To close channels 02 and 13, execute:

CLOS (@102,113)

Close channels 02 and 13. 1 is card number and 02,13 are channel numbers.

To open the channels, use OPEN (@102,113).

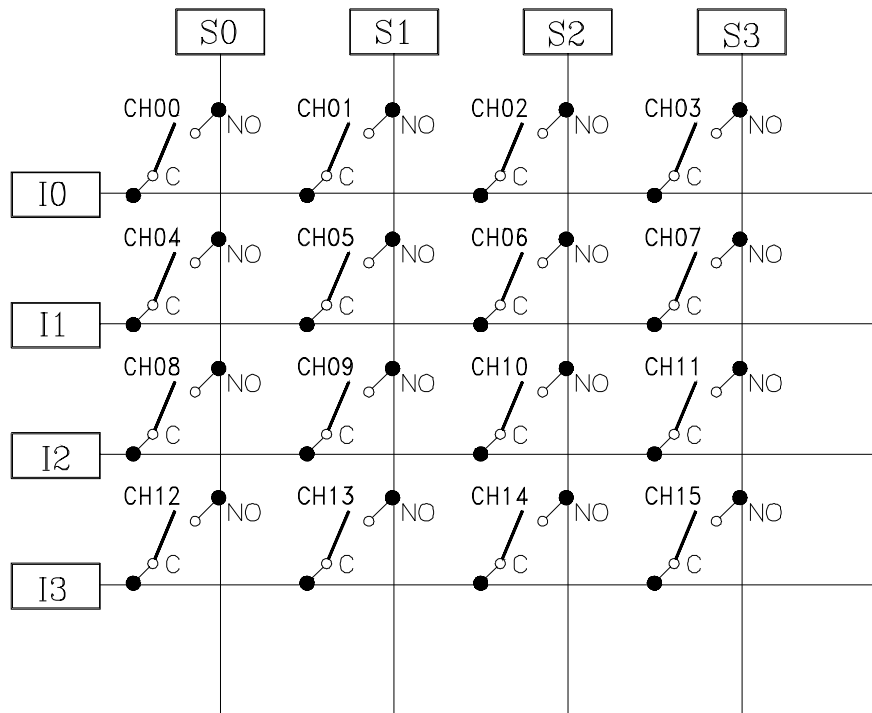

E1364A F3-5

Figure 3-5. Example: Matrix Switching

Switching Channels Comments

Query Channel States. Use ROUTe:CLOSe? <channel_list> or ROUTe:OPeN?<channel_list> to query the channel state (open/closed). ROUTe:CLOSe? returns a 1 for channel(s) closed, 0 for channel(s) open. ROUTe:OPeN? returns a 0 for channel(s) closed, 1 for channel open. (Commands are software queries and do not account for relay hardware failures.)

Channel Closure Order. ROUTe:CLOSe <channel_list> can be used to close multiple channels (one at a time), but the sequence in which multiple channels are closed with a single command is not guaranteed.

Scanning Channels

- For the Form C Switch, scanning channels consists of closing a specified set of channels, one channel at a time. You can scan any combination of channels for a single-module or a multiple-module switchbox.
- Single, multiple, or continuous scanning modes are available. See Chapter 4 for information on scanning Form C Switch channels.

Example: Scanning Using Trig Out Port

This example shows one way to synchronize instrument measurements of devices under test (DUT) with Form C Switch channel closures. For measurement synchronization, the Agilent E1300B/E1301B Trig Out BNC port is connected to the instrument External Trigger In port. See Figure 3-6 for typical user connections.

For this example, the mainframe and instrument are connected via GPIB to an Agilent E1300B/E1301B mainframe with an address of 709 and an external instrument (such as an Agilent 3457A Multimeter) with an address of 722. The Form C Switch is at logical address 120 (secondary address 15).

Note

You must add required instrument commands to line 10. Also, you may need to add a WAIT statement as line 65, depending on the speed of the measurement.

```
10 OUTPUT 722; "TRIG EXT;.. "      ! Ext triggering
20 OUTPUT 70915; "OUTP ON"        ! Enable Trig Out Port
30 OUTPUT 70915; "TRIG:SOUR BUS"  ! Bus triggering
40 OUTPUT 70915; "SCAN (@100:102)" ! Scan channels 00-02
50 OUTPUT 70915; "INIT"          ! Enable scan
60 FOR I=1 TO 3                  ! Start loop
70 ENTER 722:A                   ! Enter result
80 PRINT A                       ! Display result
90 TRIGGER 70915                 ! Advance scan
100 NEXT I                        ! Increment count
110 END
```

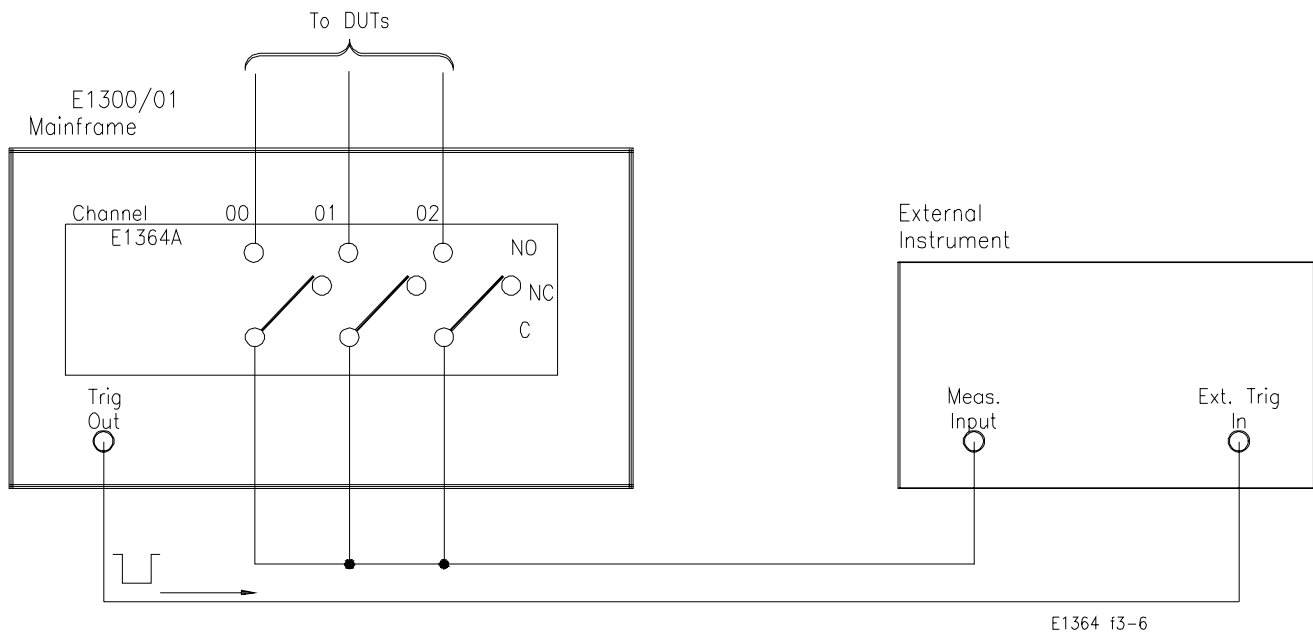

Figure 3-6. Example: Scanning Using Trig Out Port

Scanning Channels Comments

Channel List Can Extend Across Boundaries. For multiple-module switchbox instruments, the channels to be scanned can extend across switch modules. For example, for a two-module switchbox instrument, `SCAN (@100:215)` will scan all channels of both Form C Switches.

Setting Multiple/Continuous Scans. Use `ARM:COUNT <number>` to set from 1 to 32767 scans. Use `INITiate:CONTinuous ON` to set continuous scanning. See Chapter 4 for details.

Chapter 4

Understanding the Agilent E1364A Form C Switch

Using This Chapter

This chapter describes some techniques to scan Form C switch channels and to use the Scan Complete bit. In addition, this chapter describes how the instrument responds to special 488.2 commands and the SCPI query, SYStem:ERRor? The chapter contents are:

- Scanning Channels Commands Page 33
- Using Scanning Trigger Sources Page 33
- Scanning with External Instruments Page 33
- Using the Scan Complete Bit. Page 38
- Special 488.2 Commands (*RCL,*RST,*SAV) Page 39
- SCPI Error Responses Page 40

Scanning Channels Commands

Scanning Form C Switch channels consists of closing a set of channels (connecting NO to C) one channel at a time. Single scan, multiple (2 to 32767) scans, or continuous scanning modes are available. See Figure 4-1 for scanning commands.

Using Scanning Trigger Sources

TRIG:SOUR specifies the source to advance the scan. Use the TRIG command to advance the scan when TRIG:SOUR BUS or TRIG:SOUR HOLD is set. The OUTP command enables the Agilent E1300B/E1301B or Agilent E1405/E1406 Trig Out port. Figure 4-2 shows scanning trigger sources.

Scanning With External Instruments

Scanning Form C Switch channels has the same effect as executing multiple CLOSE commands. Thus, scanning is useful when the outputs from a number of devices under test (DUT) are to be measured with an instrument. Two examples using BASIC programming language follow.

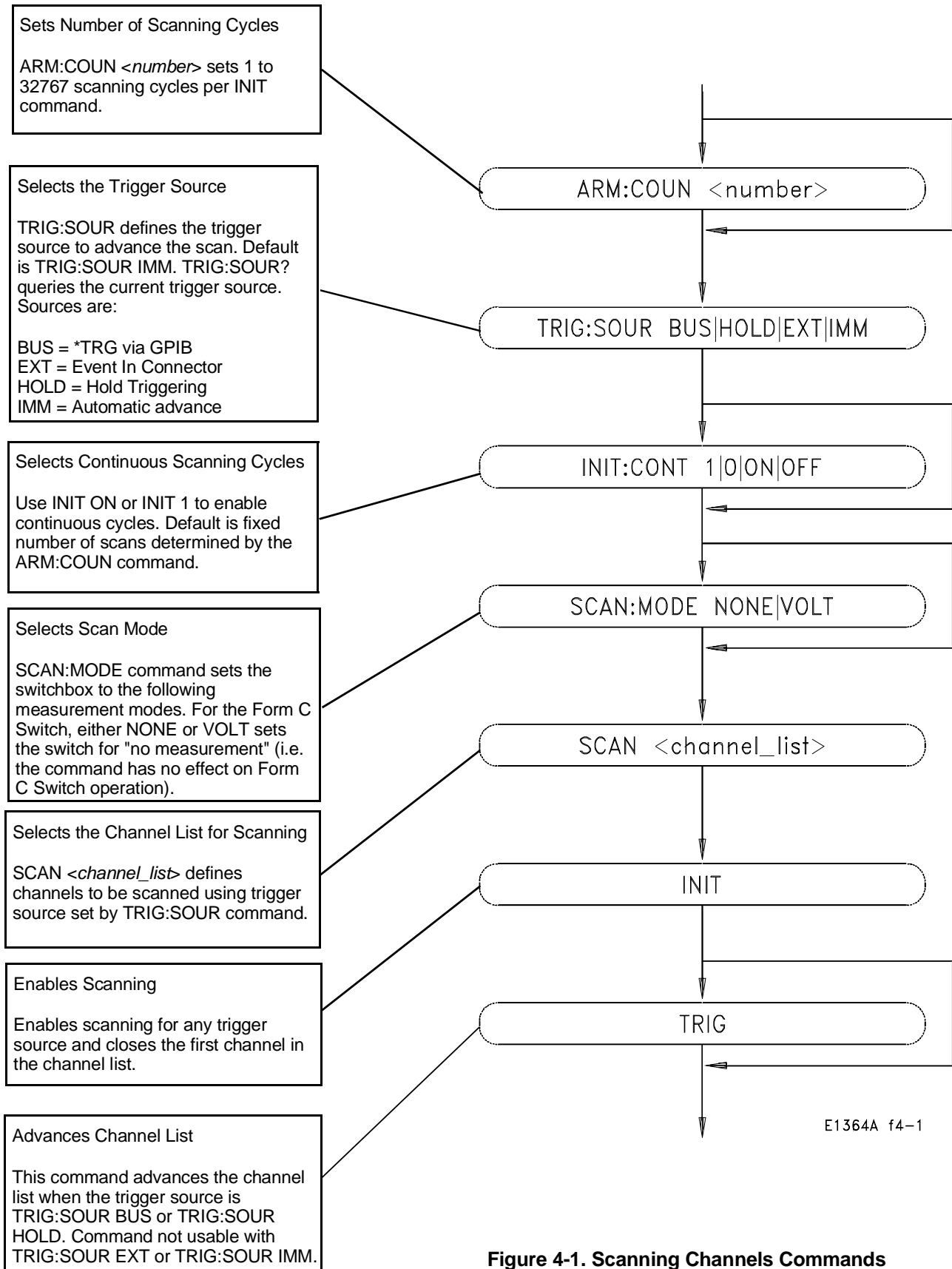

Figure 4-1. Scanning Channels Commands

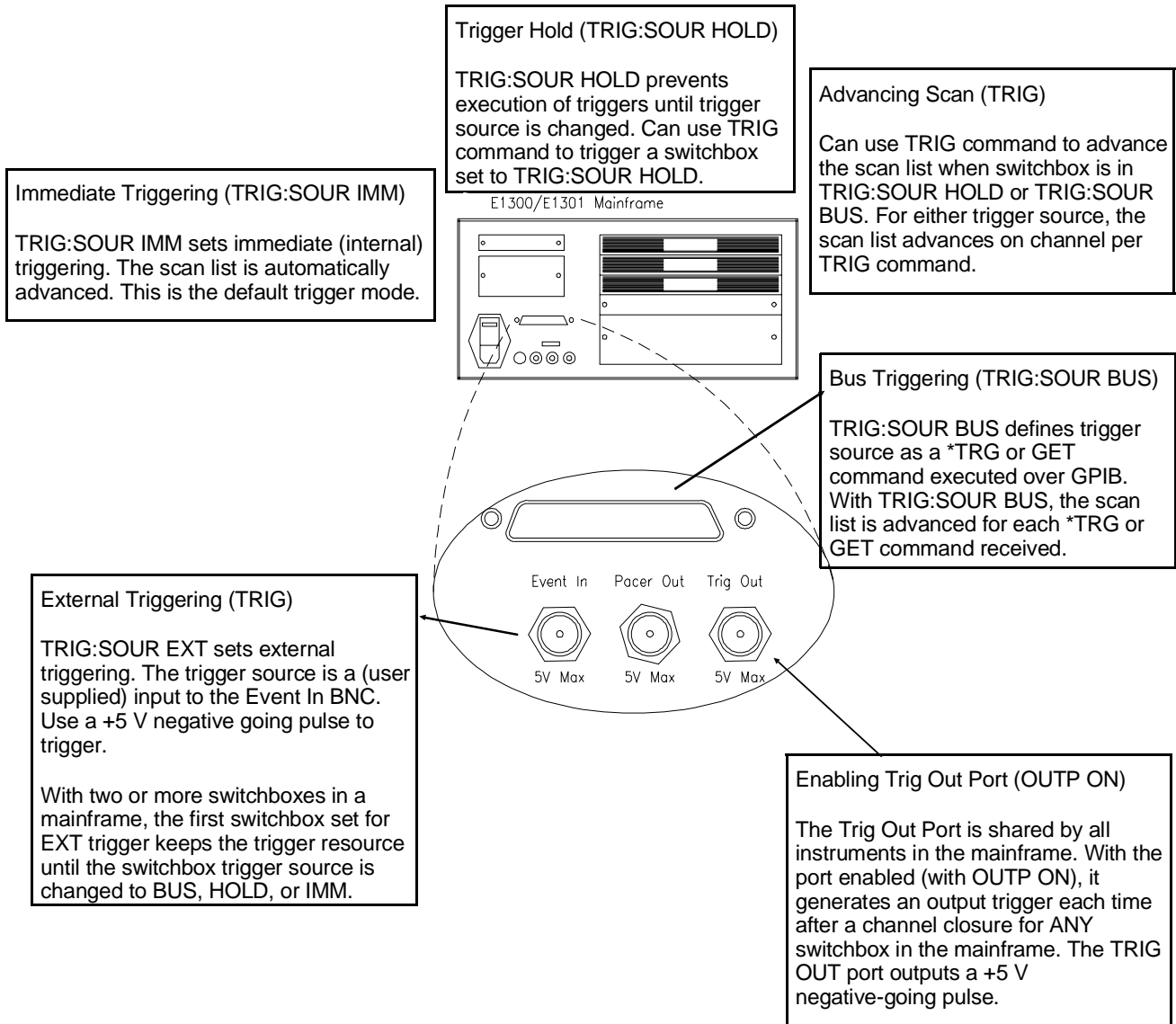

Figure 4-2. Scanning Trigger Sources

Example: Scanning With External Devices

This example uses the mainframe Trig Out port to synchronize the Form C Switch channel closures to an external measurement device. See the following figure for typical user connections. For measurement synchronization, the Agilent E1300B/E1301B Trig Out BNC port is connected to the instrument External Trigger In port. For this example, the mainframe and instrument are connected via GPIB with mainframe address of 709 and instrument address of 722. The Form C Switch is at logical address 120 (secondary address 15). The measurements are transferred directly to the computer. (Appropriate instrument commands must be added to line 10 and you may need to add a WAIT statement as line 65 for long measurements.) The sequence of operation is:

1. INIT (line 50) closes channel 100.
2. Closure causes trigger output from the Trig Out port.
3. Trigger to Ext Trig In initiates channel 100 measurement.
4. Result is sent to the computer (lines 60-80).
5. TRIGGER (line 90) advances the scan to channel 101.
6. Steps 2-5 are repeated for channels 101-102.

```

10 OUTPUT 722; "TRIG EXT;..."           ! Configure instrument
20 OUTPUT 70915; "OUTP ON"                ! Enable Trig Out port
30 OUTPUT 70915; "TRIG:SOUR BUS"         ! GPIB bus triggering
40 OUTPUT 70915; "SCAN (@100:102)"      ! Scan channels 00-02
50 OUTPUT 70915; "INIT"                  ! Enable scan
60 FOR I = 1 TO 3                          ! Start count loop
70 ENTER 722;A                             ! Enter reading
80 PRINT A                                 ! Display reading
90 TRIGGER 70915                           ! Advance scan
100 NEXT I                                 ! Increment count
110 END

```

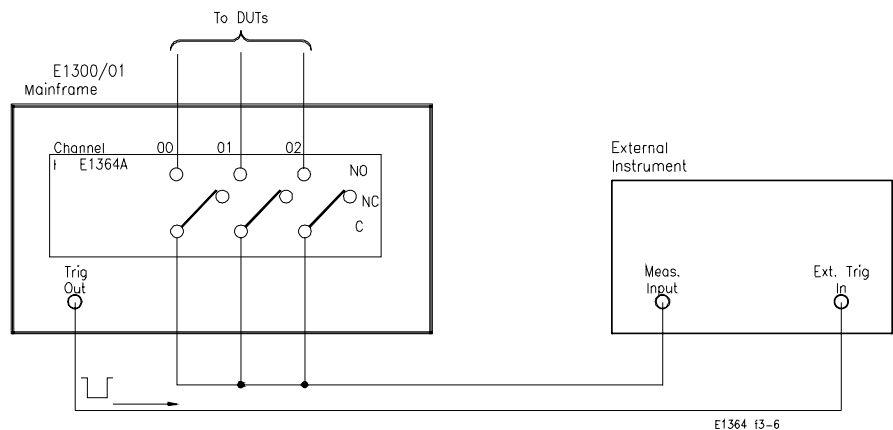

Example: Scanning Using Trig Out and Event In Ports

This example uses the mainframe Trig Out and Event In ports to synchronize Form C switch channel closures with an external measurement device. See the following figure for typical user connections. For this example, the mainframe and instrument are connected via GPIB with mainframe address of 709 and instrument address of 722. The Form C Switch logical address is 120 (secondary address = 120/8 = 15).

With this example, since synchronization with the computer cannot be ensured, the external instrument must have internal memory capacity to store the readings. Also, you must add the appropriate instrument commands to line 10. The sequence of operation is:

1. INIT (line 50) closes channel 100.
2. Closure causes trigger to be output from Trig Out port.
3. Trigger to Ext Trig In initiates channel 100 measurement.
4. Channel 100 measurement result is stored in instrument.
5. Trigger is then output from Measurement Complete port.
6. Trigger to Event In port advances scan to channel 101.
7. Steps 2-6 are repeated for channels 101-102.

10 OUTPUT 722; "TRIG EXT;..."	<i>Configure instrument</i>
20 OUTPUT 70915; "OUTP ON"	<i>Enable Trig Out port</i>
30 OUTPUT 70915; "TRIG:SOUR EXT"	<i>Event In triggering</i>
40 OUTPUT 70915; "SCAN (@100:102)"	<i>Scan channels 00 - 02</i>
50 OUTPUT 70915; "INIT"	<i>Enable scan</i>
60 END	

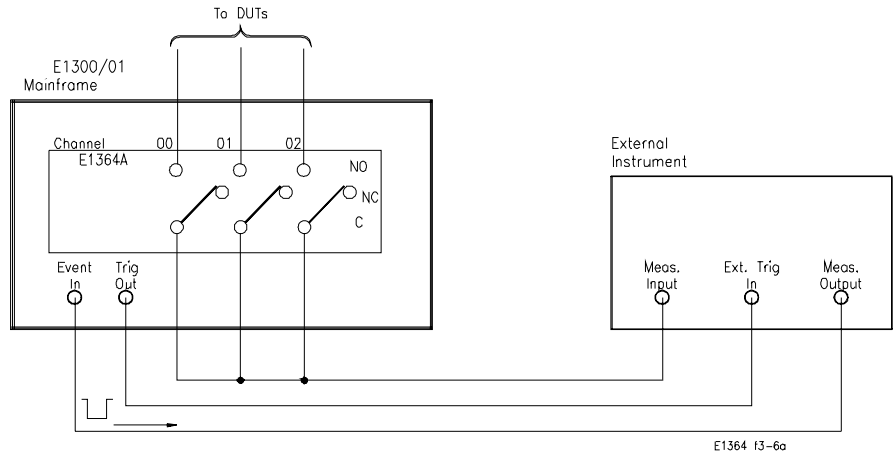

Using the Scan Complete Bit

You can use the Scan Complete bit (bit 8) in the Operation Status Register of a switchbox to determine when a scanning cycle completes (no other bits in the register apply to the switchbox). Bit 8 has a decimal value of 256 and you can read it directly with the STAT:OPER? command. See the STATus:OPERation[:EVENT]? command in Chapter 5 for an example.

When enabled by the STAT:OPER:ENAB 256 command, the Scan Complete bit will be reported as bit 7 of the Status Register. Use the GPIB Serial Poll or the IEEE 488.2 Common Command *STB? to read the Status Register.

When bit 7 of the Status Register is enabled by the *SRE 128 Common Command to assert an GPIB Service Request (SRQ), you can interrupt the computer when the Scan Complete bit is set, after a scanning cycle completes. This allows the computer to do other operations while the scanning cycle is in progress.

Example: Scan Complete Interrupt

The following example monitors bit 7 in the Status Register to determine when the scanning cycle completes. The computer used in this example is an HP 9000 Series 200/300 used with BASIC as the programming language. The computer interfaces with an Agilent E1300B/E1301B Mainframe over GPIB. The GPIB select code is 7, the GPIB primary address is 09, and the GPIB secondary address is 15.

```
10 OUTPUT 70914; "*CLS"           ! Clear all switchbox status
                                   structure
20 OUTPUT 70915; "STAT:OPER:ENAB 256"! Enable Scan Complete Bit to
                                   set bit 7 in Status Register
30 OUTPUT 70915:"*SRE 128"       ! Enable bit 7 of Status Register to
                                   assert SRQ
40 OUTPUT 70915;"TRIG:SOUR EXT"  ! Set to external trigger mode
50 OUTPUT 70915;"SCAN(@100:147)" ! Select channels to be scanned
60 OUTPUT 70915; "INIT"          ! Start scanning cycle
70 WHILE NOT BIT(S POLL(70915),7) ! Waiting for scan complete
80 PRINT "DO OTHER OPERATION HERE"! Enter program lines for
                                   computer to do other operations
90 END WHILE
100 PRINT "INTERRUPT GENERATED" ! Program goes to this line after
                                   interrupt is generated by a
                                   completed scanning cycle
110 END
```

Special 488.2 Commands

This section contains information about the response of the switchbox instrument to three IEEE 488.2 common commands.

Storing States

The `*SAV <numeric_state>` command saves the current instrument state. The state number (0-9) is specified by the `<numeric_state>` parameter. The settings saved by this command are:

- ARM:COUNT
- TRIGGER:SOURCE
- OUTPUT:STATE
- INITIATE:CONTINUOUS
- SCAN (the scan list is set to invalid; therefore, the command does not save a scan list.)
- SCAN:MODE
- SCAN:PORT

Recalling States

The `*RCL <numeric_state>` command recalls the state when the last `*SAV` was executed for the specified `<numeric_state>` parameter (0-9). If no `*SAV` was executed for the `<numeric_state>`, `*RST` default settings are used. Refer to the `*SAV` settings list for the settings recalled by `*RCL`.

The `*RST` command opens all channels, invalidates the current channel list for scanning and sets the following:

- ARM:COUNT 1
- TRIGGER:SOURCE IMM
- INIT:CONTINUOUS OFF
- OUTPUT:STATE OFF
- SCAN:MODE NONE
- SCAN PORT NONE

SCPI Error Responses

The `SYSTem:ERRor?` query requests a value from the instrument's error register. This register contains an integer in the range [-32768 to 32767].

The response takes the following form:

`<err_number>, <err_message>`

The `<err_number>` is the value of the instrument's error register. The `<err_message>` is a short description of the error, followed by further information about the error.

If no error occurs, the switchbox responds with 0,"No error". If there has been more than one error, the instrument will respond with the first one in its error queue. Subsequent queries continue to read the error queue until it is empty. The maximum `<err_message>` string length is 255 characters.

Chapter 5

Agilent E1364A Form C Switch Command Reference

Using This Chapter

This chapter summarizes Standard Commands for Programmable Instruments (SCPI) and IEEE 488.2 Common (*) commands. See the *Agilent 75000 Series B B-Size VXIbus Mainframe Agilent E1300B/E1301B User's Manual* or the *Agilent 75000 Series C Agilent E1405A User's Manual* for additional information on SCPI and common commands. Chapter contents are:

- Command Types Page 41
- SCPI Command Reference Page 44
- Common Command Reference Page 61
- Command Quick Reference. Page 62

Command Types

Commands are separated into two types: IEEE 488.2 Common Commands and SCPI commands.

Common Command Format

The IEEE 488.2 standard defines the Common Commands that perform functions like reset, self-test, status byte query, etc. Common Commands are four or five characters in length, always begin with the asterisk character (*), and may include one or more parameters. The command key word is separated from the first parameter by a space character. Some examples of Common Commands are shown below

```
*RST    *ESR 32    *STB?
```

SCPI Command Format

The SCPI commands perform functions like closing switches, making measurements, and querying instrument states or retrieving data. A subsystem command structure is a hierarchical structure that usually consists of a top-level (or root) command, one or more lower level commands, and their parameters. The following example shows part of a typical subsystem:

```
[ROUTe:]  
  CLOSe <channel_list>  
  SCAN <channel_list>  
    :MODE?
```

[ROUTe:] is the root command, CLOSe and SCAN are second-level commands, and :MODE? is a third-level command.

Command Separator

A colon (:) always separates one command from the next lower level command as shown below:

ROUTE:SCAN:MODE?

Colons separate the root command from the second-level command (ROUTE:SCAN) and the second level from the third-level (SCAN:MODE?).

Abbreviated Commands

The command syntax shows most commands as a mixture of upper- and lower-case letters. The upper case letters indicate the abbreviated spelling for the command. For shorter program lines, send the abbreviated form. For better program readability, you may send the entire command. The instrument will accept either the abbreviated form or the entire command. For example, if the command syntax shows MEASure, then MEAS and MEASURE are both acceptable forms. Other forms of MEASure, such as MEASU or MEASUR, will generate an error. You may use upper- or lower-case letters. Therefore, MEASURE, measure, and MeAsUrE are all acceptable.

Implied Commands

Implied commands are those which appear in square brackets ([]) in the command syntax. (Note that the brackets are not part of the command and are not sent to the instrument.) Suppose you send a second-level command but do not send the preceding implied command. In this case, the instrument assumes you intend to use the implied command and it responds as if you had sent it.

Examine the SOURce subsystem shown below:

```
[SOURce:]  
PULSe  
  :COUNT  
  :COUNT?  
  :PERiod  
  :PERiod?
```

The root command SOURce: is an implied command. To set the instrument's pulse count to 25, you can send either of the following command statements:

SOUR:PULS:COUN 25 or **PULS:COUN 25**

Parameters **Parameter Types.** The following table contains explanations and examples of the parameter types you might see later in this chapter.

Table 5-1. SCPI Parameter Types

Parameter Type	Explanations and Examples
Numeric	Accepts all commonly used decimal representations of numbers including optional signs, decimal points, and scientific notation. 123, 123E2, -123,-1.23E2, .123, 1.23E-2, 1.23000E-01. Special cases include MIN, MAX and INF.
Boolean	Represents a single binary condition that is either true or false. ON, OFF, 1, 0.
Discrete	Selects from a finite set of values. These parameters use mnemonics to represent each valid setting. An example is TRIGger:SOURce <source> where <source> can be BUS, EXT, HOLD, or IMM.

Optional Parameters. Parameters shown within square brackets ([]) are optional parameters. (Note that the brackets are not part of the command and are not sent to the instrument.) If you do not specify a value for an optional parameter, the instrument chooses a default value.

For example, consider the ARM:COUNT? [MIN | MAX] command. If you send the command without specifying a parameter, the present ARM:COUNT value is returned. If you send the MIN parameter, the command returns the minimum count available. If you send the MAX parameter, the command returns the maximum count available. Be sure to place a space between the command and the parameter.

Linking Commands **Linking IEEE 488.2 Common Commands with SCPI Commands:** Use a semicolon between the commands. For example:

*RST;OUTP ON or TRIG:SOUR HOLD;*RST

Linking Multiple SCPI Commands: Use both a semicolon (;) and a colon (:) between the commands. For example:

ARM:COUN 1;;TRIG:SOUR EXT

SCPI Command Reference

This section describes the Standard Commands for Programmable Instruments (SCPI) commands for the Form C Switch. Commands are listed alphabetically by subsystem and also within each subsystem.

ABORt

The ABORt command subsystem stops a scan in progress when the scan is enabled via the interface and the trigger source is TRIGger:SOURce BUS or TRIGger:SOURce HOLD.

Subsystem Syntax **ABORt**

Comments

- **ABORt Actions:** ABORt invalidates the current channel list and sets ARM:COUNT 1 (one scanning cycle per INITiate command), sets INITiate:CONTInuous OFF (no continuous scanning cycles), and sets TRIGger:SOURce IMMEDIATE (immediate internal triggering).
- **Stopping Scan Enabled From Interface:** When a scan is enabled from an interface, an interface CLEAR command or the Agilent E1301A front panel "Reset Instr" or "Clear Instr" keys can be used to stop the scan. When the scan is enabled from the interface and TRIG:SOUR BUS or HOLD is set, use ABORt or the Agilent E1301A front panel "Reset Instr" or "Clear Instr" keys to stop the scan.
- **Stopping Scan Enabled From Front Panel:** When a scan is enabled from the Agilent E1301B front panel, you can use *RST entered via the interface or the front panel "Reset Instr" or "Clear Instr" keys to stop the scan.
- **Related Commands:** ARM, INITiate:CONTInuous, [ROUTE:]SCAN, TRIGger

Example **Stopping a scan with ABORt:**

This example stops a (continuous) scan in progress.

TRIG:SOUR BUS	<i>*TRG command is trigger source</i>
INIT:CONT ON	<i>Set continuous scanning</i>
SCAN (@100:103)	<i>Scan channels 00 through 03</i>
INIT	<i>Start scan, close channel 00</i>
.	
.	
ABOR	<i>Abort scan in progress</i>

ARM

The ARM subsystem selects the number of scanning cycles (1 to 32767) for each INITiate command.

Subsystem Syntax

ARM

:COUNT <number> MIN | MAX

:COUNT? [MIN | MAX]

:COUNT

ARM:COUNT <number> MIN | MAX allows scanning cycles to occur a multiple of times (1 to 32767) with one INITiate command when INITiate:CONTinuous OFF | 0 is set. MIN sets 1 cycle, MAX sets 32767 cycles.

Parameters

Parameter Name	Parameter Type	Range of Values
<number>	numeric	1-32767 MIN MAX

Comments

- **Number of Scans:** Use only values between 1 and 32767 for the number of scanning cycles.
- **Related Commands:** ABORt, INITiate[:IMMediate]
- ***RST Condition:** ARM:COUNT 1

Example

Setting Ten Scanning Cycles:

This example sets a Form C Switch for 10 scans of channels 00 through 03. When the scan sequence completes, channels 00 through 03 (relays 00 through 03) are closed.

ARM COUN 10

Set 10 scans per INIT command

SCAN (@100:103)

Scan channels 00-03

INIT

Start scan, close channel 00

MONitor[:STATe] DISPlay:MONitor[:STATe] *<mode>* turns the monitor mode on or off.

Parameters

Parameter Name	Parameter Type	Range of Values
<i><mode></i>	boolean	ON OFF 1 0

Comments

- **Monitoring Switchbox Channels:** DISPlay:MONitor[:STATe] ON or DISPlay:MONitor[:STATe] 1 turns the monitor mode ON to show the channel state of the selected module. DISPlay:MONitor[:STATe] OFF or DISPlay:MONitor[:STATe] 0 turns the monitor mode OFF.

- **Selecting the Module to be Monitored:** Use the DISPlay:MONitor:CARD *<number>* |AUTO command to select the module.

- **Monitor Mode on an Agilent E1301B Mainframe Display:** A typical display for the Agilent E1364A Form C Switch module follows, where all channels (all relays) are closed.

0,1,2,3,4,5,6,7,8,9,10,11,12,13,14,15

- ***RST Condition:** DISPlay:MONitor[:STATe] OFF | 0

Example Enabling the Monitor Mode:

DISP:MON:CARD 2

Selects module #2 in a switchbox

DISP:MON 1

Turns monitor mode ON

INITiate

The INITiate command subsystem selects continuous scanning cycles and starts the scanning cycle.

Subsystem Syntax **INITiate**
 :**CONTinuous** <*mode*>
 :**CONTinuous**?
 [:**IMMediate**]

:CONTinuous **INITiate:CONTinuous ON | OFF | 1 | 0** enables or disables continuous scanning cycles for the switchbox.

Parameters

Parameter Name	Parameter Type	Range of Values
< <i>mode</i> >	boolean	ON OFF 1 0

Comments

- **Continuous Scanning Operation:** Continuous scanning is enabled with the INITiate:CONTinuous ON or INITiate:CONTinuous 1 command. Sending the INITiate[:IMMediate] command closes the first channel in the channel list. Each trigger from a trigger source selected by the TRIGger:SOURce command advances the scan through the channel list. A trigger at the end of the channel list closes the first channel in the channel list and the scan cycle repeats.
- **Non-Continuous Scanning Operation:** Non-continuous scanning is enabled with the INITiate:CONTinuous OFF or INITiate:CONTinuous 0 command. Sending the INITiate[:IMMediate] command closes the first channel in the channel list. Each trigger from a trigger source selected by the TRIGger:SOURce command advances the scan through the channel list. At the end of the scanning cycle, the last channel in the channel list is closed.
- **Stopping Continuous Scan:** See the ABORt command.
- **Related Commands:** ABORt, ARM:COUNt, TRIGger, TRIGger:SOURce
- ***RST Condition:** INITiate:CONTinuous OFF

Example **Enabling Continuous Scanning:**

This example enables continuous scanning of channels 00 through 03 of a single-module switchbox. Since TRIGger:SOURce IMMediate (default) is set, use an interface clear command (such as CLEAR) to stop the scan.

```
INIT:CONT ON                            Enable continuous scanning  
SCAN (@100:103)                        Defines channel list  
INIT                                      Start scan cycle, close channel 00
```

:CONTInuous? **INITiate:CONTInuous?** queries the scanning state. With continuous scanning enabled, the command returns 1. With continuous scanning disabled, the command returns 0.

Example **Query Continuous Scanning State:**

This example enables continuous scanning of a switchbox and queries the state. Since continuous scanning is enabled, INIT:CONT? returns 1.

```
INIT:CONT ON Enable continuous scanning
INIT:CONT? Query continuous scanning
```

[:IMMediate] **INITiate[:IMMediate]** starts the scanning process and closes the first channel in the channel list. Successive triggers from the source selected by the TRIGger:SOURce command advance the scan through the channel list.

Comments

- **Starting the Scanning Cycle:** The INITiate[:IMMediate] command starts scanning by closing the first channel in the channel list. Each trigger received advances the scan to the next channel in the channel list. An invalid channel list definition causes an error (see [ROUTE:]SCAN).
- **Stopping Scanning Cycles:** See ABORT.

Example **Enabling a Single Scan:**

This example enables a single scan of channels 00 through 03 of a single-module switchbox. The trigger source to advance the scan is immediate (internal) triggering set with (default) TRIGger:SOURce IMMediate.

```
SCAN (@100:103 Scan channels 00-03
INIT Begin scan, close channel 00 (use immediate triggering).
```

OUTPut

The OUTPut command subsystem enables or disables the "Trig Out" port of the Agilent E1300B/E1301B Mainframes or on the Agilent E1405/E1406 Command Modules.

Subsystem Syntax **OUTPut**
 [:STATe] <mode>
 [:STATe]?

[:STATe] **OUTPut[:STATe] <mode>** enables or disables the "Trig Out" BNC port on the rear panel of the Agilent E1300B/E1301B Mainframes or on the Agilent E1405/E1406 Command Modules. OUTPut[:STATe] ON | 1 enables the port and OUTPut[:STATe] OFF | 0 disables the port.

Parameters

Parameter Name	Parameter Type	Range of Values
<mode>	boolean	ON OFF 1 0

Comments

- **Enabling Trig Out Port:** When enabled, a pulse is output from the "Trg Out" port after each scanned switchbox channel is closed. If disabled, a pulse is not output from the port after channel closures. The output pulse is a + 5 V negative-going pulse.
- **Trig Out Port Shared by Switchboxes:** When enabled, the "Trig Out" port is pulsed each time a scanned channel is closed. To disable the output for a specific switchbox, send the OUTPut[:STATe] OFF or OUTPut[:STATe] 0 command for that switchbox.
- **Related Commands:** [ROUTE:]SCAN, TRIGger:SOURce
- ***RST Condition:** OUTPut[:STATe] OFF (port disabled)

Example Enabling Trig Out Port:

OUTP:STAT ON

Enable "Trg Out" port to output pulse after each scanned channel is closed

[:STATe]? **OUTPut[:STATe]?** queries the present state of the "Trig Out" port. The command returns 1 if the port is enabled or 0 if the port is disabled.

Example Query Trig Out Port Enable State:

This example enables the "Trig Out" port and queries the enable state. The OUTPut[:STATe]? command returns 1 since the port is enabled.

OUTP:STAT ON
OUTP:STAT?

*Enable "Trig Out" port
Query port enable state*

[ROUTe:]

The ROUTe command subsystem controls switching and scanning operations for Form C Switch modules in a switchbox.

Subsystem Syntax [ROUTe:]
CLOSE <channel_list>
CLOSE? <channel_list>
OPEN <channel_list>
OPEN? <channel_list>
SCAN <channel_list>
:MODE NONE | VOLT
:MODE?

CLOSE [ROUTe:]CLOSE <channel_list> closes the Form C Switch channels specified by *channel_list*. *channel_list* has the form (@ccnn) where cc = card number (01-99) and nn = channel number (00-15).

Parameters

Parameter Name	Parameter Type	Range of Values
<channel_list>	numeric	cc00 - cc15

Comments

- **Closing Channels:** To close a single channel, use [ROUTe:]CLOSE (@ccnn); for multiple channels use [ROUTe:]CLOSE (@ccnn,ccnn,); for sequential channels, use [ROUTe:]CLOSE (@ccnn:ccnn); for groups of sequential channels, use [ROUTe:]CLOSE (@ccnn:ccnn,ccnn:ccnn); or any combination. Closure order for multiple channels with a single command is not guaranteed.
- **Related Commands:** [ROUTe:]OPEN, [ROUTe:]CLOSE?
- ***RST Condition:** All channels open.

Example

Closing Form C Switch Channels:

This example closes channels 100 and 213 of a two-module switchbox (card numbers 01 and 02).

```
CLOS (@100,213)
```

Close channels 100 and 213. 100 closes channel 00 of card #1 and 213 closes channel 13 of card #2.

CLOSe? [ROUTE:] CLOSe? <channel_list> returns the current state of the channel(s) queried. *channel_list* has the form (@ccnn) (see [ROUTE:]CLOSe for definition). The command returns 1 if channel(s) are closed or returns 0 if channel(s) are open.

Comments

- **Query is Software Readback:** The [ROUTE:]CLOSe? command returns the current software state of the channel(s) specified. It does not account for relay hardware failures. A maximum of 127 channels at a time can be queried for a multi-module switchbox.

Example Query Channel Closure:
 This example closes channels 100 and 213 of a two-module switchbox and queries channel closure. Since the channels are programmed to be closed 1,1 is returned as a string.

```
CLOS (@100,213)           Close channels 100 and 213
CLOS? (@100,213)        Query channels 100 and 213 state
```

OPEN [ROUTE:]OPEN <channel_list> opens the Form C Switch channels specified by *channel_list*. *channel_list* has the form (@ccnn) where cc = card number (01-99) and nn = channel number (00-15).

Parameters

Parameter Name	Parameter Type	Range of Values
<channel_list>	numeric	cc00 - cc15

Comments

- **Opening Channels:** To open a single channel, use [ROUTE:]OPEN (@ccnn); for multiple channels use [ROUTE:]OPEN (@ccnn,ccnn,); for sequential channels, use [ROUTE:]OPEN (@ccnn:ccnn); for groups of sequential channels, use [ROUTE:]OPEN (@ccnn:ccnn,ccnn:ccnn); or any combination. Opening order for multiple channels with a single command is not guaranteed.
- **Related Commands:** [ROUTE:]CLOSe, [ROUTE:]OPEN?
- ***RST Condition:** All channels open.

Example Opening Channels:
 This example opens channels 100 and 213 of a two-module switchbox (card numbers 01 and 02).

```
OPEN (@100,213)           Open channels 100 and 213. 100
                           opens channel 00 of #1 and 213
                           opens channel 13 of card #2.
```

OPEN? [ROUTE:]OPEN? <channel_list> returns the current state of the channel(s) queried. *channel_list* has the form (@ccnn) (see [ROUTE:]OPEN for definition). The command returns 1 if channel(s) are open or returns 0 if channel(s) are closed.

- Comments**
- **Query is Software Readback:** The ROUTE:OPEN? command returns the current software state of the channels specified. It does not account for relay hardware failures. A maximum of 127 channels at a time can be queried for a multi-module switchbox.

Example **Query Channel Open State:**
 This example opens channels 100 and 213 of a two-module switchbox and queries channel 213 state. Since channel 213 is programmed to be open, 1 is returned.

```
OPEN (@100,213)           Open channels 100 end 213
OPEN? (@213)             Query channel 213 state
```

SCAN [ROUTE:]SCAN <channel_list> defines the channels to be scanned. *channel_list* has the form (@ccnn) where cc = card number (01-99) and nn = channel number (00-15).

Parameters

Parameter Name	Parameter Type	Range of Values
<channel_list>	numeric	cc00 - cc15

- Comments**
- **Defining Scan List:** When [ROUTE:]SCAN is executed, the channel list is checked for valid card and channel numbers. An error is generated for an invalid channel list.
 - **Scanning Channels:** You can scan single channels (@ccnn); multiple channels (@ccnn,ccnn,...); sequential channels (@ccnn:ccnn); groups of sequential channels (@ccnn:ccnn,ccnn:ccnn); or any combination.
 - **Scanning Operation:** When a valid channel list is defined, INITiate[:IMMediate] begins the scan and closes the first channel in the channel list. Successive triggers from the source specified by TRIGger:SOURce advance the scan through the channel list.
 - **Stopping Scan:** See ABORT.
 - **Related Commands:** TRIGger, TRIGger:SOURce
 - ***RST Condition:** All channels open.

Example **Scanning Using External Device:**
 See Chapter 4, "Example: Scanning With External Devices" or "Example: Scanning Using Trig Out and Event In Ports" for example scanning programs using external instruments.

SCAN:MODE

[ROUTe:]SCAN:MODE NONE | VOLT can be used for the Form C Switch. Both NONE and VOLT set the mode for "no measurements". This command has no effect on Form C Switch operation. [ROUTe:]SCAN:MODE? can be used to query the scanning mode (NONE or VOLT) for the Form C Switch.

STATus

The STATus subsystem reports the bit values of a Standard Operation Status Register. It enables the Status Register to set a bit after a bit is set to 1 by the Operation Status Register.

Subsystem Syntax

STATus
:OPERation
[:EVENT]?
ENABle <number>

:OPERation[:EVENT]?

STATus:OPERation[:EVENT]? returns the bit value of the Operation Status Register (only bit 8 is used by the Form C Switch).

Comments

- **Setting Bit 8 of the Operation Status Register:** Bit 8 (Scan Complete) is set to 1 after a scanning cycle completes. Bit 8 returns to 0 after sending the STATus:OPERation[:EVENT]? command.
- **Returned Data After Sending STATus:OPERation[:EVENT]?:** The command returns + 256 if bit 8 of the Operation Status Register is set to 1. The command returns + 0 if bit 8 of the Operation Status Register is set to 0.
- **Related Commands:** [ROUTe:] SCAN

Example

Reading the Operation Status Register After a Scanning Cycle:

STAT:OPER?

Returns the bit values of the Standard Operation Status Register. Returns + 256 if bit 8 is set to 1 or returns + 0 if bit 8 is set to 0.

:OPERation:ENABLE **STATus:OPERation:ENABLE** <number> enables the Operation Status Register to set a bit in the Status Register. For the Form C Switch, when bit 8 in the Operation Status Register is set to 1, bit 7 in the Status Register is set to 1.

Parameters

Parameter Name	Parameter Type	Range of Values
<number>	numeric	1 - 32767

- Comments**
- **Setting Bit 7 of the Status Register:** STATus:OPERation:ENABLE 256 sets bit 7 of the Status Register to 1 after bit 8 of the Operation Status Register is set to 1.
 - **Related Commands:** [ROUTE:]SCAN

Example **Enabling Status Register Bit 7:**

STAT:OPER:ENAB 256 *Enables bit 7 of Status Register*

SYSTEM

The SYSTem subsystem returns the error numbers and error messages in the error queue of a switchbox, and returns the types and descriptions of modules (cards) in a switchbox.

Subsystem Syntax **SYSTem**
:ERRor?
:CDEscription? <number>
:CTYPE? <number>
:CPON <number> |ALL

:ERRor? **SYSTem:ERRor?** returns the error numbers and corresponding error messages in the error queue of a switchbox. See Appendix C for a listing of some switchbox error numbers and messages.

- Comments**
- **Error Numbers/Messages in the Error Queue:** Each error generated by a switchbox stores an error number and corresponding error message in the error queue. The error message can be up to 255 characters long.
 - **Clearing the Error Queue:** An error number/message is removed from the queue each time the SYSTem:ERRor? command is sent. The errors are cleared first-in, first-out. When the queue is empty, each following SYSTem:ERRor? command returns 0, "No error". To clear all error numbers/messages in the queue, execute the *CLS command.

- **Maximum Error Numbers/Messages in the Error Queue:** The queue holds a maximum of 30 error numbers/messages for each switchbox. If the queue overflows, the last error number/message in the queue is replaced by -350, "Too many errors". The least recent error numbers/messages remain in the queue and the most recent are discarded.

Example Reading the Error Queue:

SYST:ERR? *Query the error queue*

:CDEescription? **SYSTEM:CDEscription? <number>** returns the description of a selected module (card) in a switchbox.

Parameters

Parameter Name	Parameter Type	Range of Values
<number>	numeric	1 - 99

Comments

- **Form C Switch Module Description:** The SYSTem:CDEscription? <number> command returns: "16 Channel General Purpose Relay"

Example Reading the Description of a Card#1 Module:

SYST:CDES? 1 *Returns the description*

:CTYPE? **SYSTEM:CTYPE? <number>** returns the module (card) type of a selected module in a switchbox.

Parameters

Parameter Name	Parameter Type	Range of Values
<number>	numeric	1 - 99

Comments

- **Form C Switch Module Model Number:** The SYSTem:CTYPE? <number> command returns:

HEWLETT-PACKARD,E1364A,0,A.01.00

where the 0 after E1364A is the module serial number (always 0) and A.01.00 is an example of the module revision code number.

Example Reading the Model Number of a Card#1 Module:

SYST:CTYP? 1 *Return the model number*

:CPON **SYSTEM:CPON <number>** | **ALL** sets the selected module (card) in a switchbox to its power-on state.

Parameters

Parameter Name	Parameter Type	Range of Values
<number>	numeric	1 - 99

Comments

- **Form C Switch Module Power-On State:** The power-on state is all channels (relays) open. Note that *RST opens all channels of all modules in a switchbox, while **SYSTEM:CPON <number>** opens the channels in only the module (card) specified in the command.

Example **Setting Card #1 Module to its Power-On State:**

SYST:CPON 1 *Sets module #1 to power-on state*

TRIGger

The TRIGger command subsystem controls the triggering operation of Form C Switch modules in a switchbox.

Subsystem Syntax

TRIGger
[:IMMEDIATE]
:SOURce BUS | EXTERNAL | HOLD | IMMEDIATE
:SOURce?

[:IMMEDIATE] **TRIGger[:IMMEDIATE]** causes a trigger event to occur when the defined trigger source is **TRIGger:SOURce BUS** or **TRIGger:SOURce HOLD**.

Comments

- **Executing the TRIGger[:IMMEDIATE] Command:** A channel list must be defined with **[ROUTE:]SCAN <channel_list>** and an **INITiate[:IMMEDIATE]** command must be executed before **TRIGger[:IMMEDIATE]** will execute.
- **BUS or HOLD Source Remains:** If selected, the **TRIGger:SOURce BUS** or **TRIGger:SOURce HOLD** commands remain in effect after triggering a switchbox with the **TRIGger[:IMMEDIATE]** command.
- **Related Commands:** **INITiate**, **[ROUTE:]SCAN**

Example Advancing Scan Using TRIGger Command

This example uses the TRIGger command to advance the scan of a single-module switchbox from channel 00 through 03. Since TRIGger:SOURce HOLD is set, the scan is advanced one channel each time TRIGger is executed.

TRIG:SOUR HOLD	<i>Sets trigger source to HOLD</i>
SCAN (@100:103)	<i>Defines channel list</i>
INIT	<i>Begin scan, close channel 00</i>
loop statements	<i>Start count loop</i>
TRIG	<i>Advance scan to next channel</i>
increment loop	<i>Increment loop count</i>

:SOURce TRIGger:SOURce BUS | EXTERNAL | HOLD | IMMEDIATE specifies the trigger source to advance the channel list during scanning.

Parameters

Parameter Name	Parameter Type	Parameter Description
BUS	discrete	*TRG or GET command
EXTERNAL	discrete	"Event In" BNC port
HOLD	discrete	Hold Triggering
IMMEDIATE	discrete	Immediate Triggering

Comments

- **Enabling the Trigger Source:** The TRIGger:SOURce command only selects the trigger source. The INITiate[:IMMEDIATE] command enables the trigger source.
- **Using the TRIG Command:** You can use TRIGger[:IMMEDIATE] to advance the scan when TRIGger:SOURce BUS or TRIGger:SOURce HOLD is selected.
- **Using External Trigger Inputs:** With TRIGger:SOURce EXTERNAL selected, only one switchbox at a time can use the external trigger input at the Agilent E1300B/E1301B mainframe "Event In" BNC port. The trigger input is assigned to the first switchbox that requested the external trigger source (with a TRIGger:SOURce EXTERNAL command).
- **Assigning External Trigger:** A switchbox assigned with TRIGger:SOURce EXTERNAL remains assigned to that source until the switchbox trigger source is changed to BUS, HOLD, or IMMEDIATE. When the source is changed, the external trigger source is available to the next switchbox which requests it (with a TRIGger:SOURce EXTERNAL command). If a switchbox requests an external trigger input already assigned to another switchbox an error is generated.

- **Using Bus Triggers:** To trigger the switchbox with TRIGger:SOURce BUS selected, use the IEEE 488.2 common command *TRG or the GPIB Group Execute Trigger (GET) command.
- **Trig Out Port Shared by Switchboxes:** See the OUTPut command.
- **Related Commands:** ABORt, [ROUte:]SCAN.
- ***RST Condition:** TRIGger:SOURce IMMEDIATE

Examples Scanning Using External Triggers:

This example uses external triggering (TRIG:SOUR EXT) to scan channels 00 through 03 of a single-module switchbox. The trigger source to advance the scan is the input to the "Event In" BNC on an Agilent E1300B/E1301B Mainframe. When INIT is executed, the scan is started and channel 00 is closed. Then each trigger received at the "Event In" BNC advances the scan to the next channel.

TRIG:SOUR EXT	<i>Select external triggering</i>
SCAN (@100:103)	<i>Scan channels 00 through 03</i>
INIT	<i>Begin scan, close channel 00</i>
trigger externally	<i>Advance scan to next channel</i>

Scanning Using Bus Triggers:

This example uses bus triggering (TRIG:SOUR BUS) to scan channels 00 through 03 of a single-module switchbox. The trigger source to advance the scan is the *TRG command (as set with TRIGger:SOURce BUS). When INIT is executed, the scan is started and channel 00 is closed. Then, each *TRG command advances the scan to the next channel.

TRIG:SOUR BUS	<i>Select interface (bus) triggering</i>
SCAN(@100:103)	<i>Scan channels 00 through 03</i>
INIT	<i>Start scan, close channel 00</i>
loop statement	<i>Loop to scan all channels</i>
*TRG	<i>Advance scan using bus triggering</i>
increment loop	<i>Increment loop count</i>

:SOURce? **TRIGger:SOURce?** returns the current trigger source for the switchbox. Command returns BUS, EXT, HOLD, or IMM for sources BUS, EXTERNAL, HOLD, or IMMEDIATE, respectively.

Example Query Trigger Source:

This example sets external triggering and queries the trigger source. Since external triggering is set, TRIG:SOUR? returns EXT.

TRIG:SOUR EXT	<i>Set external trigger source</i>
TRIG:SOUR?	<i>Query trigger source</i>

IEEE 488.2 Common Commands

The following table lists the IEEE 488.2 Common (*) Commands that apply to the Form C Switch module. The operation of some of these commands is described in Chapter 4 of this manual. For more information on Common Commands, refer to the *Agilent 75000 Series B Mainframe (Agilent Model Number E1300B/E1301B) User's Manual* or the *ANSI/IEEE Standard 488.2-1987*.

Command	Title	Description
*IDN? *RST	Identification Reset	Returns identification string of the switchbox Opens all channels, and invalidates current channel list for scanning. Sets ARM:COUN 1, TRIG:SOUR IMM, and INIT:CONT OFF.
*TST?	Self-Test	Always returns 0.
*OPC *OPC? *WAI	Operation Complete Operation Complete Query Wait to Complete	See note below See note below See note below
*CLS *ESE *ESE? *ESR? *SRE *SRE? *STB?	Clear status Event status enable Event status enable query Event status register query Service request enable Service request enable query Read status byte query	Clears all status registers (see STATUS:OPERation[:EVENT]?) See note below See note below See note below Enables status register bits (see Chapter 4 for operation) See note below See note below
*TRG	Trigger	Triggers the switchbox to advance the scan when scan is enabled and trigger source is TRIGger:SOURce BUS
*RCL *SAV	Recall instrument state Store instrument state	See note below See note below
<p>Note: These commands apply to many instruments and are not documented in detail here. See the <i>Agilent 75000 Series B E1300B/E1301B Mainframe User's Manual</i> or the <i>ANSI/IEEE Standard 488.2-1987</i> for more information.</p>		

Command Quick Reference

SCPI Commands Quick Reference

Command	Description
ABORt	Abort a scan in progress.
ARM :COUNT <number> :COUNT? [MIN MAX]	Multiple scans per INIT command. Query number of scans.
DISPlay :MONitor:CARD <number> AUTO :MONitor[:STATe] <mode>	Selects module to be monitored. Selects monitor mode.
INITiate :CONTInuous <mode> :CONTInuous? [:IMMEDIATE]	Enables/disables continuous scanning. Query continuous scan state. Starts a scanning cycle.
OUTput [:STATe] <mode> [:STATe]?	Enables/disables "Trig Out" pulse. Query port enable state.
[ROUTE:] CLOSe <channel_list> CLOSe? <channel_list> OPEN <channel_list> OPEN? <channel_list> SCAN <channel_list> SCAN:MODE NONE VOLT SCAN:MODE?	Close channel(s). Query channel(s) closed. Open channel(s). Query channel(s) opened. Define channels for scanning. Sets scan mode. Query the Scan Mode.
STATus :OPERation:ENABle :OPERation[:EVENT]?	Enables the Operation Status Register to set a bit in the Status Register. Returns status of Operation Status Register.
SYSTem :CDEscription? <number> :CPON <number> ALL :CTYPe? <number> :ERRor?	Returns description of module in a switchbox. Sets specified module to its power-on state. Returns the module type. Returns error number/message in a switchbox Error Queue.
TRIGger [:IMMEDIATE] :SOURce BUS :SOURce EXTernal :SOURce HOLD :SOURce IMMEDIATE :SOURce?	Causes a trigger to occur. Trigger source is *TRG. Trigger source is "Event In" BNC. Hold off triggering. Continuous (internal) triggers. Query scan trigger source.

IEEE 488.2 Common Commands Quick Reference

Command	Title	Description
*RST	Reset	Opens all channels, and invalidates current channel list for scanning. Sets ARM:COUN 1, TRIG:SOUR IMM, and INIT:CONT OFF.
*TRG	Bus Trigger	When scan is enabled and trigger source is TRIG:SOUR BUS, use the *TRG command to trigger the switchbox to advance the scan.
*TST?	Self-Test	Always returns 0.

Appendix A

Agilent E1364A Form C Switch Specifications

Maximum Input Voltage:

C to NC or NO:	Any term. to chassis:
250VDC	250VDC
250VAC RMS	250VAC RMS
354VAC Peak	354VAC Peak

Maximum Current:

Per switch:	1A DC
	1A AC RMS

Maximum Power:

Per switch:	40W DC
	40VA AC
Per module:	320W DC
	320VA AC

Thermal Offset: $<7\mu\text{V}$ per chan.

Closed Channel Resistance:

$< 1.5\Omega$ /contact (initial)
 $< 3.5\Omega$ at end of relay life

Insulation Resistance: (between any two points)

$>10^7\Omega$ at $\leq 40^\circ\text{C}$, 65% RH
 $>10^8\Omega$ at $\leq 25^\circ\text{C}$, 40% RH

Bandwidth: -3dB at 10 MHz (typical)

Crosstalk, Channel to Channel: (typical)

≤ 100 kHz: ≤ 80 dB
 ≤ 10 MHz: ≤ 30 dB

Power Available:

+5V @ 1A
+12V @ 0.5 A

Insertion Loss:

≤ 100 kHz: 0.1dB
 ≤ 10 MHz: 3.0dB

Capacitance:

C to NC or NO: <20 pF
Chan. to Chan.: <20 pF

Relay Life (typical):

No load: $>10^6$ operations
Max. load: $>10^5$ operations

Power Up/Down States: all open / left in last state

Terminals: screw type, max. wire size 16 AWG

Module Size/Device Type: B, register-based

Connectors Used: P1

No. Slots: 1

VXIbus Interface Capability: Interrupter, D16

Interrupt Level: 1-7, selectable

Power Requirements:

Voltage:	+5	+12
Peak module		
current, IPM (A):	0.10	0.24
Dynamic module		
current, IDM (A):	0.01	0.01

Watts/Slot: 1.0

Cooling/Slot: 0.02 mm H₂O @ 0.10 liter/sec

Humidity: 65% to 40°C

Operating Temperature: 0 to 55°C

Storage Temperature: -40 to 75°C

EMC, RFI, Safety: meets FTZ 1046/1984,
CSA 556B, IEC 348, UL 1244

Net Weight (kg): 0.7

Relay Life

Electromechanical relays are subject to normal wear-out. Relay life depends on several factors. The effects of loading and switching frequency are briefly discussed below:

Relay Load. In general, higher power switching reduces relay life. In addition, capacitive/inductive loads and high inrush currents (e.g., turning on a lamp or starting a motor) reduce relay life. *Exceeding specified maximum inputs can cause catastrophic failure.*

Switching Frequency. Relay contacts heat up when switched. As the switching frequency increases, the contacts have less time to dissipate heat. The resulting increase in contact temperature also reduces relay life.

End of Life Detection

A preventative maintenance routine can prevent problems caused by unexpected relay failure. The end of the life of the relay can be determined by using the three methods described below. The best method (or combination of methods), as well as the failure criteria, depends on the application in which the relay is used.

Contact Resistance. As the relay begins to wear out, its contact resistance increases. When the resistance exceeds a predetermined value, the relay should be replaced.

Stability of Contact Resistance. The stability of the contact resistance decreases with age. Using this method, the contact resistance is measured several (5-10) times, and the variance of the measurements is determined. An increase in the variance indicates deteriorating performance.

Number of Operations. Relays can be replaced after a predetermined number of contact closures. However, this method requires knowledge of the applied load and life specifications for the applied load.

Replacement Strategy

The replacement strategy depends on the application. If some relays are used more often, or at a higher load, than the others, the relays can be individually replaced as needed. If all the relays see similar loads and switching frequencies, the entire circuit board should be replaced when the end of life approaches. The sensitivity of the application should be weighed against the cost of replacing relays with some useful life remaining.

Note

Relays that wear out normally or fail due to misuse should not be considered defective and are not covered by the product's warranty.

Appendix B

Agilent E1364A Form C Switch Registers

Register Definitions

The Agilent E1364A Form C Switch is a register-based device.
See Figure B-1 for register definitions.

ID Register

b + 00 ₁₆	15	14	13	12	11	10	9	8	7	6	5	4	3	2	1	0
Write	Undefined								(Logical Address)							
Read*	Reg-Base		A16		Manufacturer ID											

* Returns FFF₁₆ = Agilent A16 only register-based

Device Type Register

b + 02 ₁₆	15	14	13	12	11	10	9	8	7	6	5	4	3	2	1	0
Write	Undefined															
Read*	1 (A16 only)				Module ID Code											

* Returns: FF20₁₆ = 16-Channel Form C Switch

Status/Control Register

b + 04 ₁₆	15	14	13	12	11	10	9	8	7	6	5	4	3	2	1	0
Write*	Undefined															
Read**	FF ₁₆								B	7F ₁₆						

* R = Switch reset to power-on state (all switches open)

** B = Status "busy" is true low in bit #7 (FF7F₁₆)

Channel Enable Register

b + 08 ₁₆	15	14	13	12	11	10	9	8	7	6	5	4	3	2	1	0
Write*	CH15	CH14	CH13	CH12	CH11	CH10	CH9	CH8	CH7	CH6	CH5	CH4	CH3	CH2	CH1	CH0
Read	Always Returns FFFF ₁₆															

Write "1" closes channel, write "0" opens channel
(close = connect NO to C, open = connect NC to C)

Figure B-1. Form C Switch - Register Definitions

Addressing the Registers

To read or write to specific registers, you must use the register address. Since the addresses for Agilent 75000 Series B or Series C plug-in modules are A00 through A15, use the VME A16 mnemonic for the address space. The address space within the mainframe/command module memory map depends on the mainframe/command module used. For example, the address of the Agilent E1300B/E1301B Mainframe starts at $1F0000_{16}$.

In the Agilent E1300/E1301, the A16 space is divided so modules are addressed only at locations beginning with $C000_{16}$ within A16. Each module is allocated 64 register addresses (40_{16}). The module base address is related to the logical address set by the logical address switch (LADDR) on the module:

$$\text{base address (hexadecimal)} = (\text{logical address}_{16}) * 40_{16} + C000_{16}$$

For the Form C Switch, the factory-set logical address is 120 (78), so the base address = $(78_{16}) * (40_{16}) + C_{16} = DE00_{16}$. Then, for example, to address the Status/Control register of a Form C Switch in an Agilent E1300B/E1301B, the register address = $[A16 \text{ location}]_{16} + [\text{base address}]_{16} + [\text{register offset}]_{16} = 1F0000_{16} + DE00_{16} + 04_{16} = 1FDE04_{16}$.

Reading the Registers

You can read the following Form C Switch registers:

- ID register (base + 00_{16})
- Device Type register (base + 02_{16})
- Status/Control register (base + 04_{16})
- Channel Enable register (base + 08_{16})

ID/Device Type Registers

For the Form C Switch, a read of the ID register (base address + 00_{16}) returns $FFFF_{16}$ since the multiplexers are manufactured by Agilent and are A16 only, register-based devices. The Device Type register (base + 02_{16}) returns $FF20_{16}$.

Status/Control Register

Each relay requires about 15 msec execution time (close to open or open to close) during which time the switch is "busy". A read of the Status/Control register (base + 04_{16}) returns $FFFF_{16}$ when the module is not busy or returns $FF7F_{16}$ (bit 7 is low-true) when the module is busy.

Channel Enable Register A read of the Channel Enable register (base + 08₁₆) always returns FFFF₁₆, regardless of the channel states.

Writing to the Registers

You can write to the following Form C Switch registers:

- Status/Control register (base + 04₁₆)
- Channel Enable register (base + 08₁₆)

The only write allowed to the Status/Control register (base + 04₁₆) is to bit 0. Writing a "1" to bit 0 resets the switch (all channels open) You must then write a "0" to bit 0 to complete the reset.

Note All relays are latching and will remain in the last state during power-down and power-up unless a reset occurs. A reset connects all channel common (C) terminals to the corresponding normally closed (NC) terminals. Any combination of channel open or closed states is allowed.

Channel Enable Register Writes to the Channel Enable register (base + 08₁₆) enable you to open or close the desired channel (see Figure B-1). For example, write a "1" to bit 2 of the Channel Enable register to close channel 02. Or, write a "0" to bit 14 of the register to open channel 14.

Appendix C

Agilent E1364A Form C Switch Error Messages

Table C-1 lists the error messages associated with the Form C Switch module programmed by SCPI. See the appropriate mainframe manual for a complete list of error messages.

Table C-1. Form C Switch Error Messages

No.	Title	Potential Cause(s)
-211	Trigger ignored	Trigger received when scan not enabled. Trigger received after scan complete. Trigger too fast.
-213	Init Ignored	Attempting to execute an INIT command when a scan is already in progress.
-224	Illegal parameter value	Attempting to execute a command with a parameter not applicable to the command.
1500	External trigger source already allocated	Assigning an external trigger source to a switchbox when the trigger source has already been assigned to another switchbox.
2000	Invalid card number	Addressing a module (card) in a switchbox that is not part of the switchbox.
2001	Invalid channel number	Attempting to address a channel of a module in a switchbox that is not supported by the module (e.g., channel 99 of a multiplexer module).
2006	Command not supported on this card	Sending a command to a module (card) in a switchbox that is unsupported by the module.
2008	Scan list not initialized	Executing a scan without the INIT command.
2009	Too many channels in channel list	Attempting to address more channels than available in the switchbox.
2012	Invalid Channel Range	Invalid channel(s) specified in SCAN <i><channel_list></i> command. Attempting to begin scanning when no valid <i><channel_list></i> is defined.
2600	Function not supported on this card	Sending a command to a module (card) in a switchbox that is not supported by the module or switchbox.
2601	Channel list required	Sending a command requiring a <i><channel_list></i> without the <i><channel_list></i> .

!

- *CLS 61
- *ESE 61
- *ESE? 61
- *ESR? 61
- *IDN? 61
- *OPC 61
- *OPC? 61
- *RCL 61
- *RST 61
- *SAV 61
- *SRE 61
- *SRE? 61
- *STB? 61
- *TRG 61
- *TST? 61
- *WAI 61
- +12 Volts 13, 22
- +12V Jumpers 20
- +5 V Jumpers 20
- +5 Volts 13, 22
- 488.2 Commands 379
- :COUNT
- COUNT 45

A

- Abbreviated Commands 42
- ABORT Subsystem 44
- Address
 - Channel 13
- Addressing Registers 66
- ARM Subsystem 45
- ARM:COUNT 45
- ARM:COUNT? 46

C

- Card Numbers 14
- :CDEscription? 57
- Certification 7
- Channel Addresses 11
- Channel List 35

- Channel Numbers 14
- Channel Registers 65, 67
- CLOSE 52
- CLOSE? 53 - 54
- Colon (:) in commands 42
- Command Quick Reference 62
- Command Reference 41 - 62
- Command Separator 42
- Command Types 41
- Commands
 - Abbreviated 42
 - Common Commands 41
 - Implied 42
 - Linking 43
 - Parameters 43
 - SCPI 41
 - Separator 42
- Common Command Format 41
- Common Commands 63
- Configuration 13, 20
- Conformity, declaration 7
- Connecting User Inputs 18
- Connector, Front Panel 24
- Connectors 18
- :CONTinuous 49
- :CONTinuous? 50
- Control Register 65 - 66
- Controlling Microwave Relays 27
- Controlling RF Switches/Step Attenuators 28
- :COUNT? 46
- :CPON 58
- :CTYPe? 57

D

- Declaration of conformity 7
- Defintions, Register 65 - 68
- Defintition, Instrument 13
- Device Type Register 65 - 66
- Digital Output Configuration 22, 29
- DISP:MON:CARD 47
- DISP:MON[:STAT] 48
- DISPlay Subsystem 47
- Documentation history 6

E

Enable Scanning 34
End of Relay Life 64
:ERRor 56
Error Messages 69 - 70
Error Responses 40
Event In Port 37
Example
 Controlling Microwave Relays 27
 Controlling RF Switches/Step Attenuators 28
 Digital Output Configuration 29
 Matrix Switching 30
 Scan Complete Interrupt 38
 Scanning Using Trig Out and Event In Ports 37
 Scanning Using Trig Out Port 31
 Scanning with External Instruments 36
 Voltage Switching 26
External Instruments 33, 36

F

Field Wiring 18
Form C Switch Description 11
Front Panel 24
Fuses 23

G

General Purpose Relay Configuration 20

H

Agilent 8761 RF Switches 28

I

ID Register 65 - 66
IEEE 488.2 Common Commands 63
[:IMMEDIATE] 50, 58
Implied Commands 42
INIT:CONTInuous 49
INIT:CONTInuous? 50
INIT[:IMM] 25
INIT[:IMMEDIATE] 50
Initial Operation 15
INITiate Subsystem 49
Instrument Definition 11
Interrupt PriorityLogical Address 23

J

Jumpers 12, 22

L

Latching Relay 12
Linking Commands 43

M

Mainframes 13
Matrix Switching 30
Microwave Relays 27
Module Description 13
Module Numbers 14
MON:CARD 47
MON[:STAT] 48

O

OPEN 53
Operation Status Register 38
Operation, Basic 11
Operation, Initial 15
:OPERation:ENABLE 56
:OPERation[:EVENT]? 55
OUTP[:STAT] ON 25
OUTPut Subsystem 51
OUTPut[:STATe] 51
OUTPut[:STATe]? 51

P

Parameters, Commands 43
Programming the Switchbox 13

Q

Quick Reference 62

R

*RCL 39
Reading Registers 66
Recalling States 39
Register Addressing 66
Register Reading 66
Registers 65 - 68
Relay Configuration 20
Relay Control Configuration 20
Relay Life 64

Relay Replacement Strategy 64
Relays, Form C 12
RF Switches 28
[ROUT:]CLOS 25
[ROUT:]CLOS? 25
[ROUT:]OPEN 25
[ROUT:]SCAN 25
[ROUTe:] Subsystem 52
[ROUTe:]CLOSe 52
[ROUTe:]CLOSe? 53
[ROUTe:]OPEN 53
[ROUTe:]OPEN? 54
[ROUTe:]SCAN 54
[ROUTe:]SCAN:MODE 55

S

Safety warnings 6
*SAV 39
SCAN 54
Scan Complete Bit 38
Scan Cycles 34
Scan Mode 34
Scan, Stopping 44
SCAN:MODE 55
Scanning Channels 31, 33
Scanning using Trig Out Port 31
Scanning with External Instruments 33, 36
Schematic 12
SCPI command Format 41
SCPI Error Responses 40
Simplified Schematic 12
:SOURce 59
:SOURce? 60
Specifications 63 - 64
[:STATe] 51
[:STATe]? 51
STATus Subsystem 55
Status/Control Register 65 - 66
STATus:OPERation:ENABLE 56
STATus:OPERation[:EVENT]? 55
Step Attenuators 28
Stopping a Scan 44
Storing States 39
Switch Channel Addresses 13
Switch Channel Numbers 14
Switch Description 11
Switch Registers 65 - 68
Switchbox 13
Switching Channels 26
SYSTem Subsystem 56
SYSTem:CDEscription? 57
SYSTem:CPON 58

SYSTem:CTYPe? 57
SYSTem:ERRor? 40, 56

T

Terminal Block 18
Terminal Connector 24
Trig Out 37
Trig Out Port 25
Trig Outp Port 31
TRIG:SOURce 25
Trigger Source 34
Trigger Sources 33, 35
TRIGger Subsystem 58
TRIGger[:IMMediate] 58
TRIGger:SOURce 59
TRIGger:SOURce? 60

V

Voltage Switching 26

W

WARNINGS 6
Warranty 5
Wiring 24
Wiring Diagram (module) 12
Writing to Registers 67

